

Jansen Art'15

Lieferprogramm und Verarbeitung

Jansen Art'15

Programme de livraison et usinage

Jansen Art'15

Sales range and assembly

Hinweise
Remarque
Notice

Jansen Stahlssysteme
Systèmes en acier Jansen
Jansen Steel Systems

Lieferprogramm Jansen Art'15

Version 06/2021
Artikelnummer K1179474

Programme de livraison Jansen Art'15

Version 06/2021
Numéro d'article K1179474

Sales range Jansen Art'15

Version 06/2021
Item number K1179474

Eine Liste der aktuellen
Änderungen und Ergänzungen
finden Sie am Ende des Kataloges!

Une liste des dernières
modifications et ajouts est
disponible à la fin du catalogue!

A table of actual modifications
and additions can be found at
the end of the catalogue!

Bei grau hinterlegten Artikeln
muss die Verfügbarkeit angefragt
werden.

Pour les produits marqués en gris,
la disponibilité doit être demandée.

Items which are marked in grey,
the stock availability needs to be
inquired.

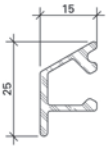

000.000

Wetterschenkel
Aluminium roh

Gewicht 0,266 kg/m
U = 0,100 m²/m
P = 0,034 m²/m

Länge 6 m

000.000

Renvoi d'eau
aluminium brut

poids 0,266 kg/m
U = 0,100 m²/m
P = 0,034 m²/m

Longueur 6 m

000.000

Weatherbar
aluminium mill finish

weight 0,266 kg/m
U = 0,100 m²/m
P = 0,034 m²/m

Length 6 m

Artikel, welche rot durchgestrichen
sind, wurden aus dem Sortiment
genommen.

Les articles barrés en rouge ont
été retirés de la gamme.

Articles that have a red line through
them have been removed from the
product range.

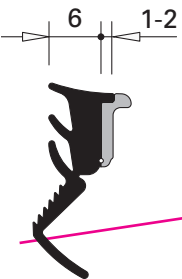

000.000

**Glasdichtung
mit Abreisstege**
EPDM, schwarz,
für Glasleistenseite

Einsatz siehe Seiten 34/35

VE = 100 m

000.000

**Joint de vitrage
avec partie déchirable**
EPDM, noir,
pour côté parclose

Utilisation voir pages 34/35

UV = 100 m

000.000

**Glazing weatherstrip
with detachable strip**
EPDM, black,
for glazing bead side

Application see pages 34/35

PU = 100 m

Inhaltsverzeichnis
Sommaire
Content

Jansen Art'15
Jansen Art'15
Jansen Art'15

Systemübersicht

Merkmale
Zulassungen
Typenübersicht

Sommaire du système

Caractéristiques
Homologations
Sommaire des types

Summary of system

Characteristics
Authorisations
Summary of types

2

Profilsortiment

Profilübersicht
Profile im Massstab 1:1
Glasleistenübersicht

Assortiment de profilé

Sommaire des profilés
Profilés à l'échelle 1:1
Sommaire des parcloses

Range of profiles

Summary of profiles
Profiles on scale 1:1
Summary of glazing beads

8

Zubehör

Zubehör
Beschläge

Accessoires

Accessoires
Ferrures

Accessories

Accessories
Fittings

40

Beispiele

Anwendungsbeispiele
Verarbeitungshinweise

Exemples

Exemples d'application
Indications d'usinage

Examples

Examples of applications
Assembly instructions

56

Leistungseigenschaften

Caractéristiques de performance

Performance characteristics

79

Merkmale
Caractéristiques
Characteristics

Jansen Art'15
 Jansen Art'15
 Jansen Art'15

- Elegante Türserie für die Innenanwendung mit filigranen Stahlrahmen und grosser Verglasung
- Äusserst schlanke und ästhetische Profilsérie mit 10 mm Kammer- und 15 mm Lappenmass
- Türprofile mit Innen- und Aussendichtung
- Bautiefe 50 mm, flächenbündig oder aufschlagend
- Verschiedene Glasleisten-Möglichkeiten in Stahl und Aluminium: normale Glasleisten, Winkelkonturglasleisten, Versiegelung mit Renoseal
- Schwelienausbildung mit automatischer Senkdichtung oder Schleifdichtung
- Schallschutz bis R_w 44 (-2;-7) db
- **Profilsystem speziell für Objektlösungen**

- Série de portes élégante pour l'utilisation en intérieur avec cadres fins en acier et grand vitrage
- Série de profilés extrêmement fins et esthétiques, dimension de chambre 10 mm et de lèvre 15 mm
- Profilés de porte avec joint intérieur et joint extérieur
- Profondeur de construction 50 mm, à fleur ou à recouvrement
- Différentes parclores possibles en acier et aluminium: parclores normales, parclores en acier à contour angulaire, scellement avec Renoseal
- Seuil à joint de seuil automatique ou à lèvre
- Isolation phonique jusqu'à R_w 44 (-2;-7) db
- **Système de profilés spécial pour solutions système**

- Elegant door series for use inside with slimline steel frames and large glazing
- Extremely narrow and aesthetically pleasing profile series with 10 mm chamber and 15 mm lip dimension
- Door profiles with internal and external weatherstrip
- Basic depth of 50 mm, flush-fitted or face-fitted
- Different glazing bead options in steel and aluminium: standard glazing beads, contoured glazing beads, sealing with Renoseal
- Threshold construction with automatic floor seal or threshold weatherstrip
- Sound insulation up to bis R_w 44 (-2;-7) db
- **Profile system especially for project solutions**

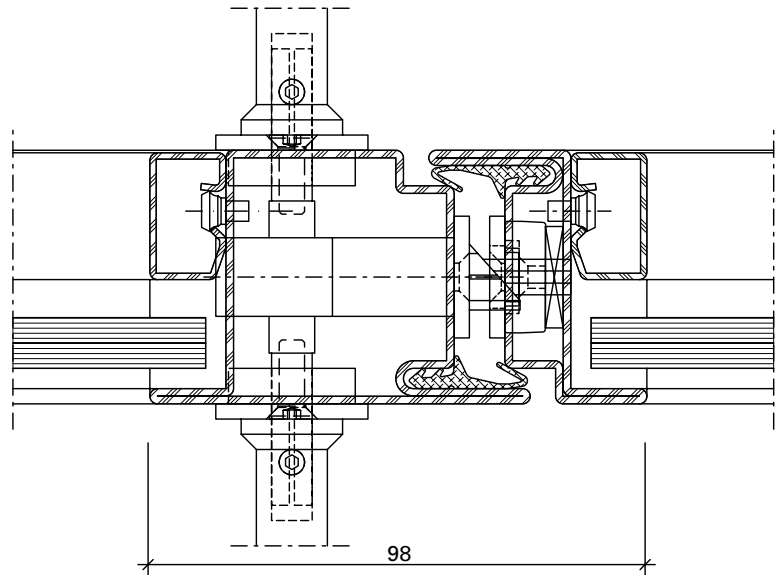
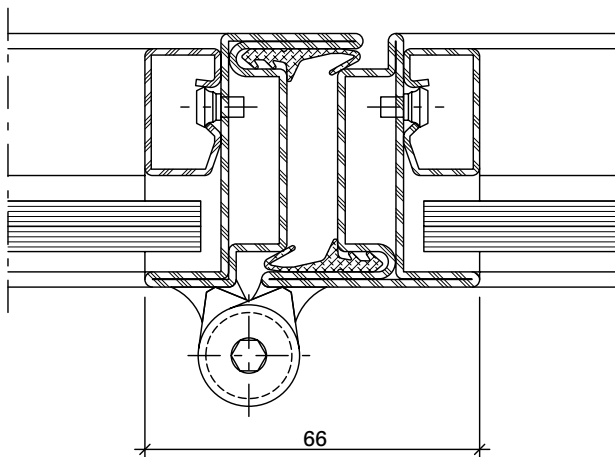

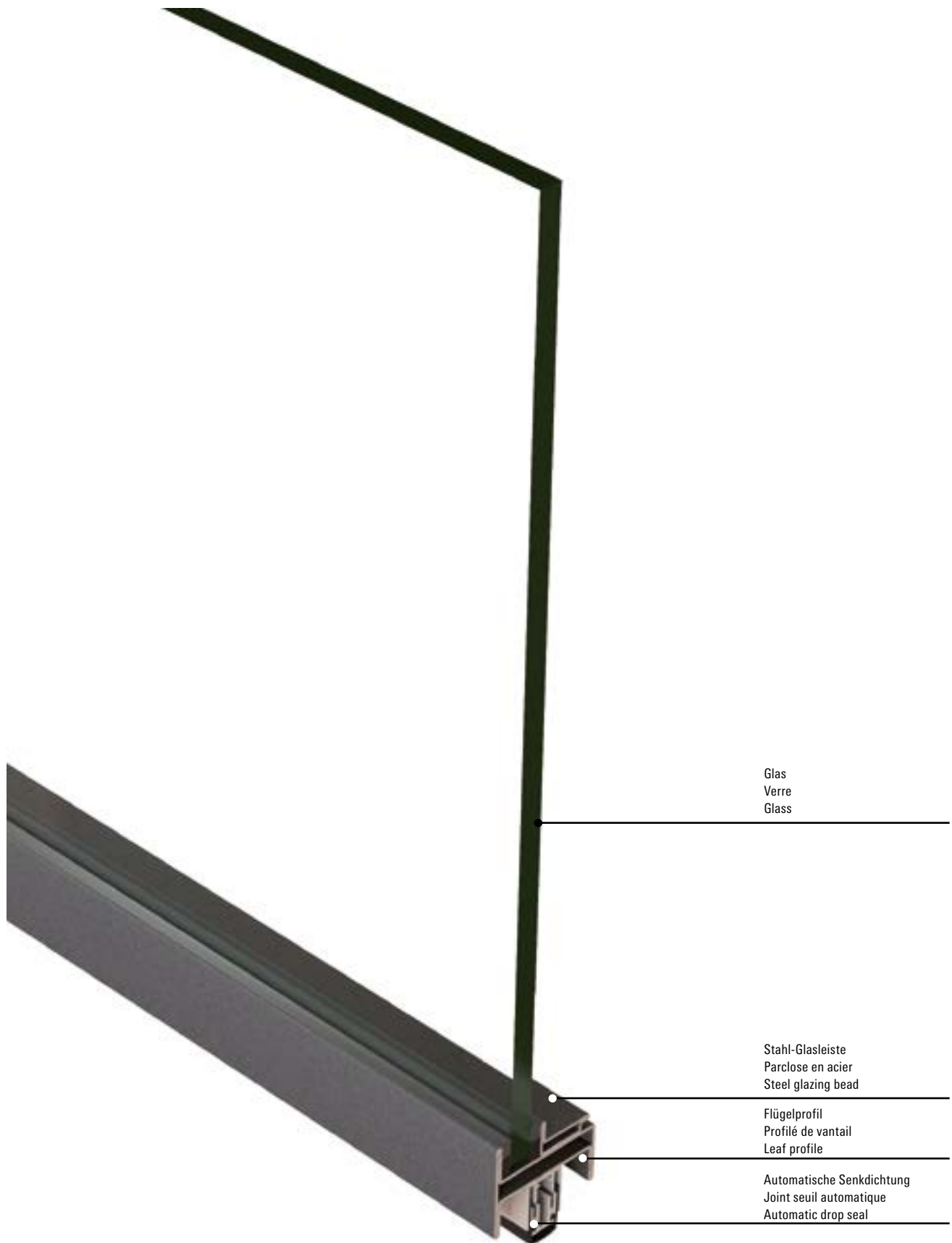

JANIsoft

JANIsoft ermöglicht die Planung, Kalkulation und Konstruktion von Jansen Systemen für Fenster, Türen und Fassaden in 2D sowie 3D. Mit der neuen Version können Planer und Verarbeiter Angebote und Bestellungen mit den entsprechenden Detailzeichnungen und Berechnungen einfach erstellen. Dank der optimierten Softwarefunktionen lässt sich der Prozess von der Arbeitsvorbereitung über die Fertigung noch effizienter gestalten.

JANIsoft

JANIsoft permet l'étude, le calcul et la construction de systèmes Jansen en 2D et 3D pour les fenêtres, les portes et les façades. La nouvelle version permet aux projeteurs et aux transformateurs d'établir facilement des offres et des commandes avec les plans de détail et les calculs. Des préparatifs du travail à la commande de la machine, le processus peut être coordonné de manière encore plus efficace grâce aux fonctions optimisées du logiciel.

JANIsoft

JANIsoft allows Jansen systems for windows, doors and façades to be planned, calculated and designed in 2D and 3D. Using the new version, developers and fabricators can easily create quotations and orders with the corresponding detailed drawings and calculations. Thanks to optimised software functionality, the procedure from process planning to fabrication can be made even more efficient.

Jansen Docu Center

Die Plattform zum effizienten Arbeiten mit Jansen Dokumentationen. Im Jansen Docu Center stehen alle Produktinformationen jederzeit digital in der aktuellsten Version zur Verfügung: von Architekten-Informationen über Bestell- und Fertigungskatalogen bis hin zu Anleitungen und Prospekten sowie Videos.

Die Inhalte können einfach und schnell aufgerufen werden. Ein für den Anwender komfortables papierloses Arbeiten, das zahlreiche Vorteile bietet.

Jansen Docu Center

La plate-forme pour travailler efficacement avec les documentations Jansen. Le Jansen Docu Center met à votre disposition les informations sur les produits, en format numérique et dans une version actualisée: des catalogues de commande et de fabrication aux instructions et prospectus, en passant par les informations destinées aux architectes et vidéos.

Les contenus sont facilement et rapidement accessibles. Une manière de travailler confortable et offrant de nombreux avantages.

Jansen Docu Center

The platform for working efficiently with Jansen documentation. The latest version of all the product information is available digitally at any time in the Jansen Docu Center – from order and fabrication manuals to architect information, instructions and brochures and videos.

The content can be retrieved quickly and easily. The user can work conveniently without paper, which has numerous benefits.

Download CAD Daten

DXF

DWG

Sie können die Zeichnungen in den Formaten DXF und/oder DWG herunterladen. Klicken Sie auf das entsprechende Icon und der Download erfolgt.

Die Hinweise «Artikelbibliothek/Türbeschläge/Fensterbeschläge» bedeuten, dass Sie mit einem Klick die gesamte Artikelbibliothek des entsprechenden Systems herunterladen (Profile, Beschläge, Glasleisten, Zubehör etc.).

Télécharger fichiers DAO

DXF

DWG

Vous pouvez télécharger les dessins aux formats DXF et/ou DWG. Cliquez sur l'icône correspondante et le téléchargement s'effectuera.

Les indications «Bibliothèque des articles/Ferures de porte/Ferures de fenêtres» signifie que vous téléchargez la totalité de la bibliothèque des articles du système donné (profilés, ferrures, parclofes, accessoires etc.).

Download CAD files

DXF

DWG

You can download the drawings in DXF and/or DWG format. Click on the relevant icon to begin the download.

The items «Article library/Door fittings/Window fittings» means that you download the entire article library for the corresponding system with one click (profiles, fittings, glazing beads, accessories etc.).

Technische Daten
Données techniques
Technical data

Jansen Art'15
 Jansen Art'15
 Jansen Art'15

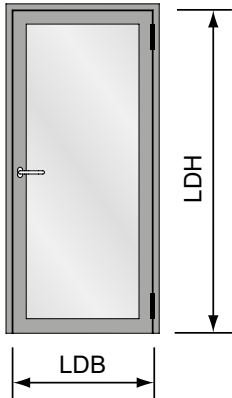

Elementgrößen

LDB Lichte Durchgangsbreite
 min. 240 mm
 max. 900 mm

LDH Lichte Durchgangshöhe
 max. 2400 mm

Flügelgewicht max. 100 kg

Dimensions des éléments

LDB Largeur libre de passage
 min. 240 mm
 max. 900 mm

LDH Hauteur libre de passage
 max. 2400 mm

Poids de vantail max. 100 kg

Size of elements

LDB Inside width
 min. 240 mm
 max. 900 mm

LDH Inside height
 max. 2400 mm

Weight of leaf max. 100 kg

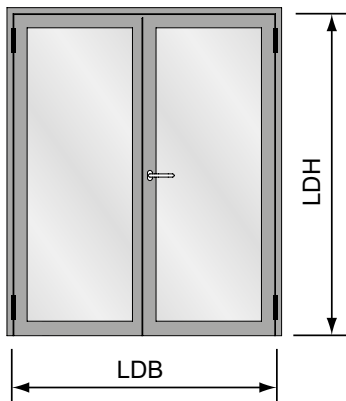

Elementgrößen

LDB Lichte Durchgangsbreite
 min. 480 mm
 max. 1800 mm

LDH Lichte Durchgangshöhe
 max. 2400 mm

Flügelgewicht max. 100 kg

Dimensions des éléments

LDB Largeur libre de passage
 min. 480 mm
 max. 1800 mm

LDH Hauteur libre de passage
 max. 2400 mm

Poids de vantail max. 100 kg

Size of elements

LDB Inside width
 min. 480 mm
 max. 1800 mm

LDH Inside height
 max. 2400 mm

Weight of leaf max. 100 kg

Keine CE-Kennzeichnung möglich

Pas de marquage CE possible

CE marking is not possible



**Bedienungs-, Pflege- und
Wartungsanleitung (598.461)**

**Instructions d'emploi, d'entretien
et de maintenance (598.468)**

**Operating and maintenance
instructions (598.467)**



**Verarbeitung Jansen-Profilsysteme
(598.477)**

**Usinage systèmes de profilés Jansen
(598.491)**

**Fabrication of Jansen profile
systems (598.492)**



Toleranzen

Tolérances

Tolerances

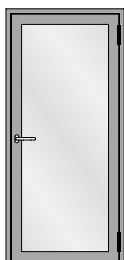

Einflügelige Türe
Porte à un vantail
Single leaf door

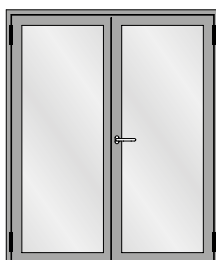

Zweiflügelige Türe
Porte à deux vantaux
Double leaf door

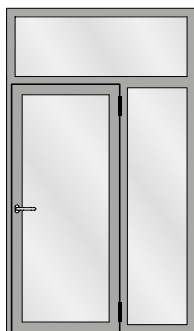

Einflügelige Türe mit Seitenteil und Oberlicht
Porte à un vantail avec partie latérale et imposte
Single leaf door with side light and top light

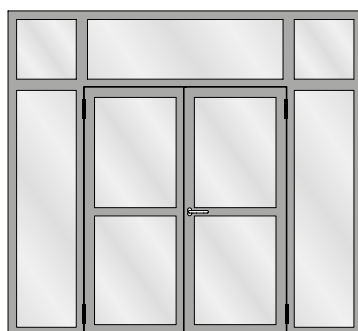

Zweiflügelige Türe mit zwei Seitenteilen und Oberlichtern
Porte à deux vantaux avec deux parties latérales et impostes
Double leaf door with two side lights and top lights



Festverglasung
Vitrage fixe
Fixed glazing

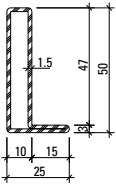

01.115

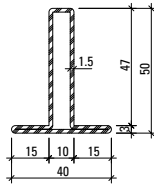

02.115

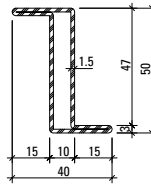

03.115

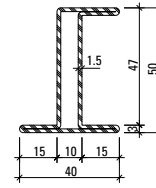

05.115

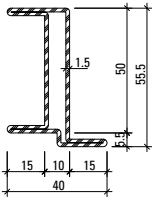

05.116

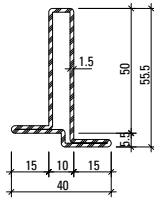

02.116

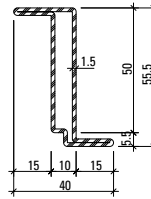

03.116

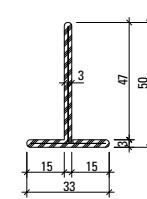

400.020

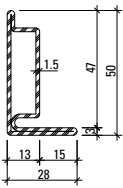

30.005

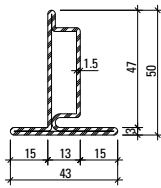

30.105

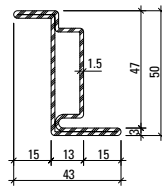

30.405

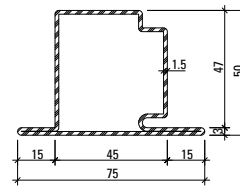

30.109

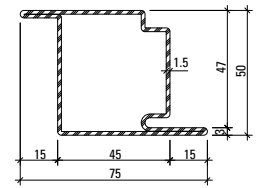

30.409

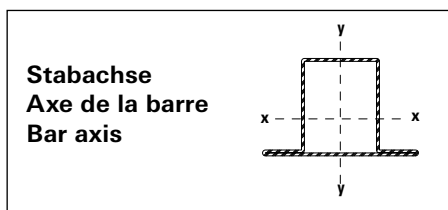

Stabachse
Axe de la barre
Bar axis

Artikelbibliothek
 Bibliothèque des articles
 Article library

DXF

DWG

| Profil-Nr. | G kg/m | F cm ² | I _x cm ⁴ | W _x cm ³ | I _y cm ⁴ | W _y cm ³ | U m ² /m |
|----------------|-----------|----------------------|-----------------------------------|-----------------------------------|-----------------------------------|-----------------------------------|------------------------|
| 01.115 | 1,660 | 2,11 | 6,10 | 2,04 | 0,89 | 0,51 | 0,145 |
| 02.115 | 2,010 | 2,26 | 7,37 | 2,23 | 1,78 | 0,89 | 0,175 |
| 03.115 | 2,010 | 2,56 | 9,05 | 3,62 | 1,78 | 0,89 | 0,175 |
| 05.115 | 2,350 | 3,00 | 11,13 | 3,91 | 2,43 | 1,11 | 0,204 |
| 05.116 | 2,470 | 3,15 | 13,01 | 4,28 | 2,46 | 1,14 | 0,214 |
| 02.116 | 2,120 | 2,70 | 8,67 | 2,47 | 1,79 | 0,89 | 0,185 |
| 03.116 | 2,120 | 2,70 | 11,31 | 4,03 | 1,79 | 0,89 | 0,185 |
| 400.020 | 1,840 | 2,35 | 6,04 | 1,80 | 0,86 | 0,50 | 0,162 |

| Profil-Nr. | G kg/m | F cm ² | I _x cm ⁴ | W _x cm ³ | I _y cm ⁴ | W _y cm ³ | U m ² /m |
|---------------|-----------|----------------------|-----------------------------------|-----------------------------------|-----------------------------------|-----------------------------------|------------------------|
| 30.005 | 1,918 | 2,44 | 6,55 | 2,06 | 1,32 | 0,67 | 0,170 |
| 30.105 | 2,250 | 2,86 | 7,57 | 2,21 | 2,29 | 1,04 | 0,199 |
| 30.405 | 2,249 | 2,87 | 9,86 | 3,61 | 2,29 | 1,04 | 0,199 |
| 30.109 | 3,020 | | 13,90 | 4,36 | 16,76 | 4,39 | |
| 30.409 | 3,017 | | 15,61 | 5,86 | 16,76 | 4,39 | |

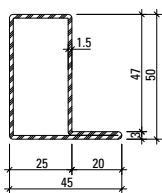

01.534
01.534 Z

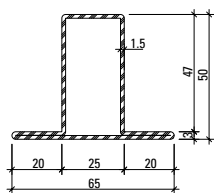

02.534
02.534 Z

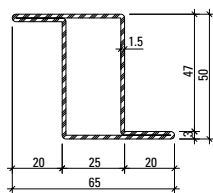

03.534
03.534 Z

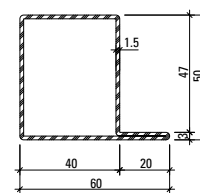

01.564
01.564 Z

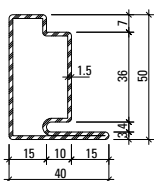

30.006
30.006 Z

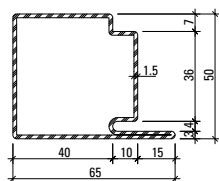

30.007
30.007 Z

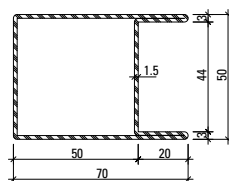

04.568
04.568 Z

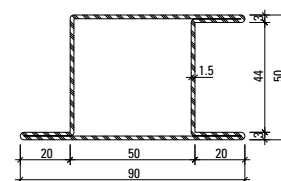

05.568
05.568 Z

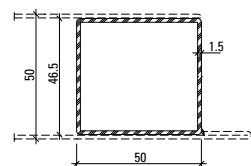

400.049 Z

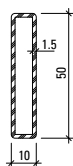

50x10x1,5*

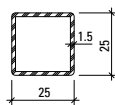

25x25x1,5*



50x5*

* Durch Metallbauer
 * Par le métallier
 * By metal constructor

Werkstoffe

Artikel-Nr.
ohne Zusatz = blank
mit Z = bandverzinkter Stahl

Matériaux

No. d'article
sans supplément = brut
avec Z = bande d'acier zinguée

Materials

Part no.
without addition = bright
with Z = strip galvanised steel

| Profil-Nr. | G kg/m | F cm ² | I _x cm ⁴ | W _x cm ³ | I _y cm ⁴ | W _y cm ³ | U m ² /m |
|---------------|-----------|----------------------|-----------------------------------|-----------------------------------|-----------------------------------|-----------------------------------|------------------------|
| 01.564 | 2,490 | 3,17 | 12,10 | 4,12 | 11,20 | 3,25 | 0,216 |
| 30.006 | 2,330 | 2,97 | 9,31 | 3,00 | 3,96 | 1,62 | 0,190 |
| 30.007 | 2,960 | 3,77 | 14,23 | 4,78 | 16,30 | 4,64 | 0,240 |
| 01.534 | 2,130 | 2,71 | 9,35 | 3,11 | 4,78 | 1,73 | 0,185 |
| 02.534 | 2,590 | 3,30 | 10,99 | 3,30 | 8,56 | 2,63 | 0,224 |
| 03.534 | 2,590 | 3,30 | 10,99 | 3,30 | 8,56 | 2,63 | 0,224 |

| Profil-Nr. | G kg/m | F cm ² | I _x cm ⁴ | W _x cm ³ | I _y cm ⁴ | W _y cm ³ | U m ² /m |
|----------------|-----------|----------------------|-----------------------------------|-----------------------------------|-----------------------------------|-----------------------------------|------------------------|
| 04.568 | 3,190 | 4,06 | 17,76 | 7,11 | 21,77 | 6,20 | 0,275 |
| 05.568 | 3,639 | 4,65 | 20,62 | 7,37 | 32,39 | 6,55 | 0,315 |
| 400.049 | 2,200 | 2,77 | 10,61 | 4,24 | 9,49 | 4,08 | 0,190 |

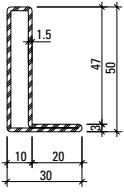

01.531
01.531 Z

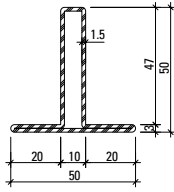

02.531
02.531 Z

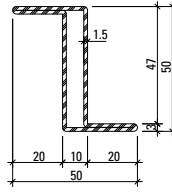

03.531

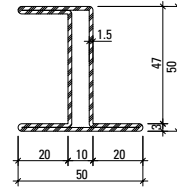

05.531 Z

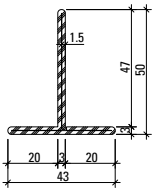

400.023
400.023 Z

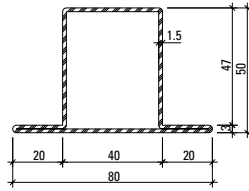

02.564
02.564 Z

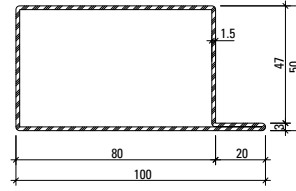

01.592
01.592 Z

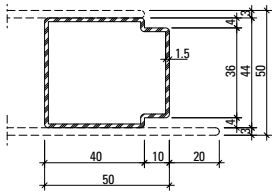

81.009 Z

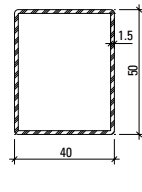

400.048
400.048 Z

Werkstoffe

Artikel-Nr.

ohne Zusatz = blank

mit Z = bandverzinkter Stahl

Matériaux

No. d'article

sans supplément = brut

avec Z = bande d'acier zinguée

Materials

Part no.

without addition = bright

with Z = strip galvanised steel

| Profil-Nr. | G kg/m | F cm ² | I _x cm ⁴ | W _x cm ³ | I _y cm ⁴ | W _y cm ³ | U m ² /m |
|----------------|-----------|----------------------|-----------------------------------|-----------------------------------|-----------------------------------|-----------------------------------|------------------------|
| 01.531 | 1,881 | 2,26 | 6,55 | 2,11 | 1,42 | 0,67 | 0,155 |
| 02.531 | 2,240 | 2,86 | 8,00 | 2,31 | 3,26 | 1,30 | 0,195 |
| 03.531 | 2,240 | 2,85 | 10,63 | 4,25 | 3,25 | 1,30 | 0,194 |
| 05.531 | 2,700 | 3,44 | 13,37 | 4,61 | 4,53 | 1,64 | 0,234 |
| 400.023 | 2,657 | 2,62 | 6,63 | 1,87 | 1,91 | 0,88 | 0,182 |

| Profil-Nr. | G kg/m | F cm ² | I _x cm ⁴ | W _x cm ³ | I _y cm ⁴ | W _y cm ³ | U m ² /m |
|----------------|-----------|----------------------|-----------------------------------|-----------------------------------|-----------------------------------|-----------------------------------|------------------------|
| 02.564 | 2,950 | 3,75 | 13,90 | 4,31 | 17,60 | 4,40 | 0,255 |
| 01.592 | 3,430 | 4,37 | 19,30 | 6,86 | 46,9 | 8,80 | 0,296 |
| 81.009 | 2,090 | 2,67 | 7,79 | 3,54 | 9,63 | 3,76 | 0,182 |
| 400.048 | 2,024 | 2,58 | 9,46 | 3,78 | 6,70 | 3,35 | 0,177 |

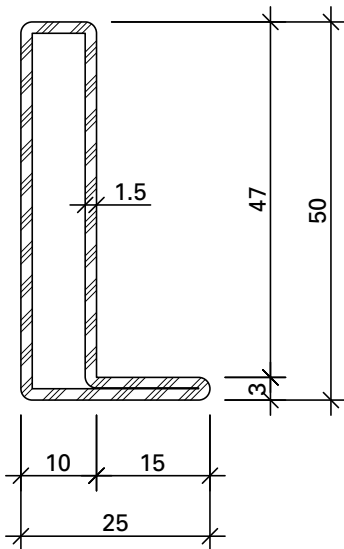

01.115

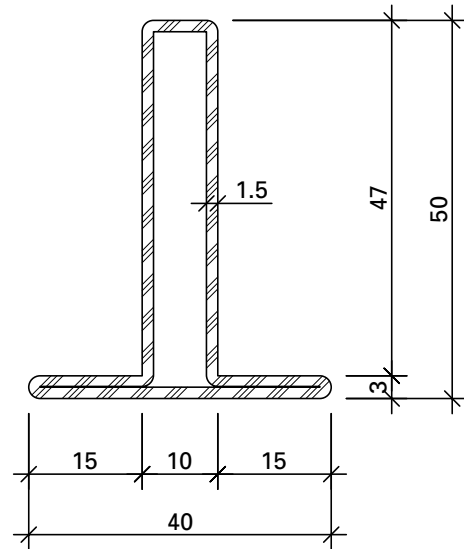

02.115

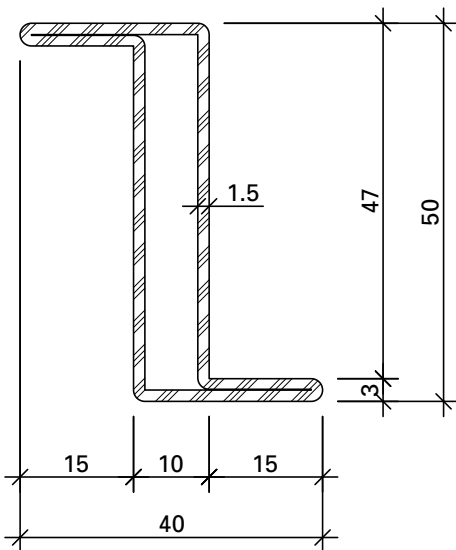

03.115

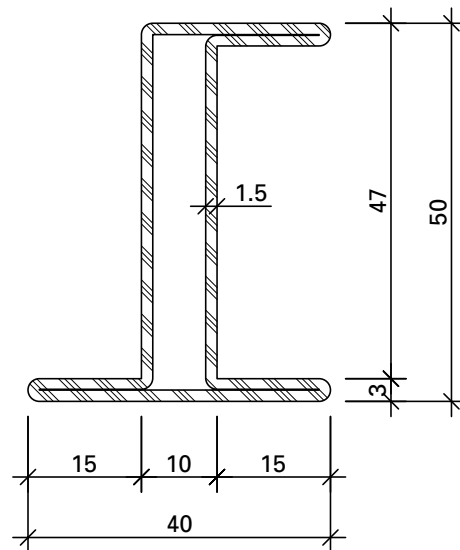

05.115

Werkstoffe

ohne Zusatz = blank
mit Z = bandverzinkter Stahl

Matériaux

sans supplément = brut
avec Z = bande d'acier zinguée

Materials

without addition = bright
with Z = strip galvanised steel

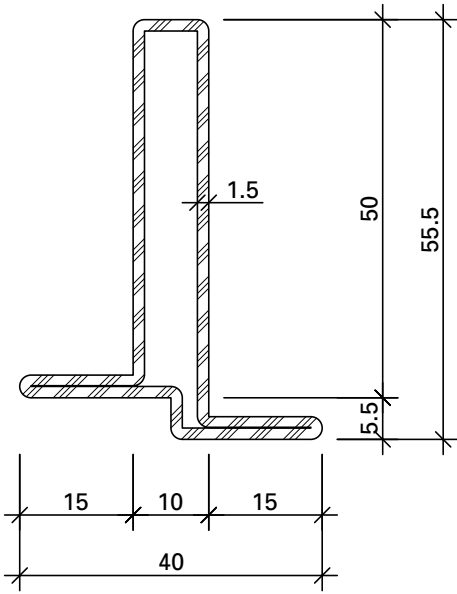

02.116

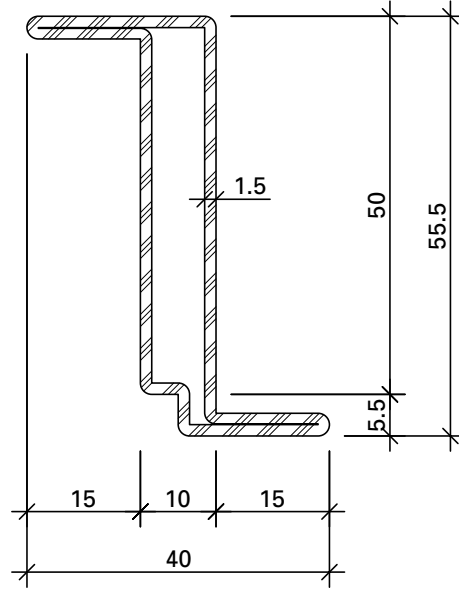

03.116

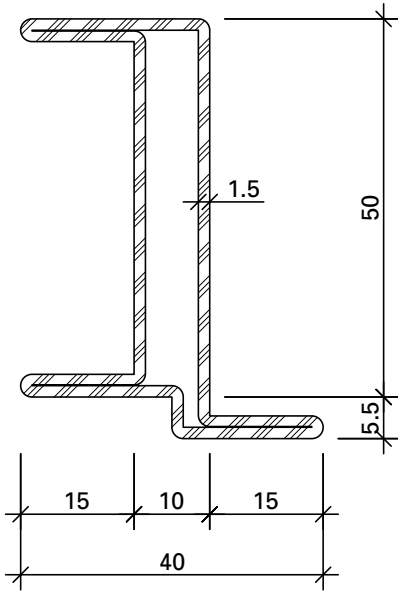

05.116

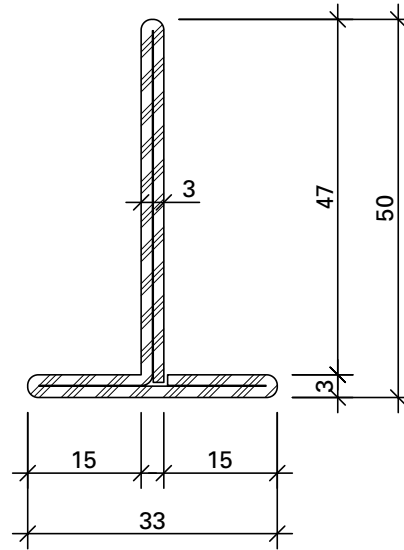

400.020

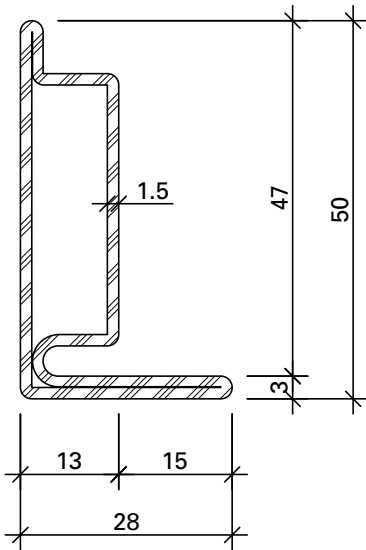

30.005

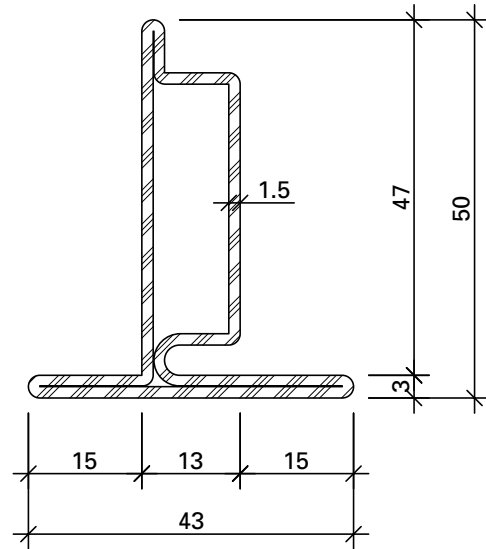

30.105

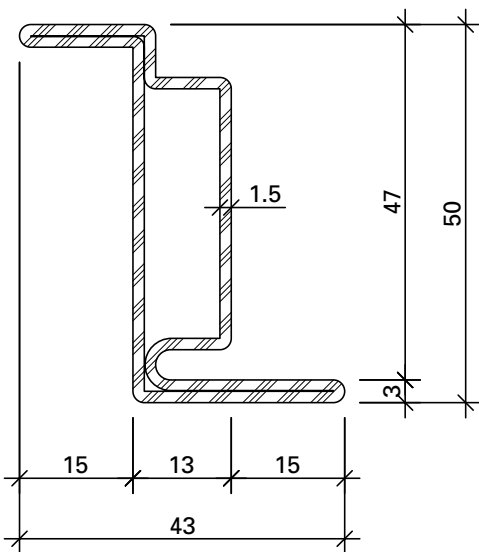

30.405

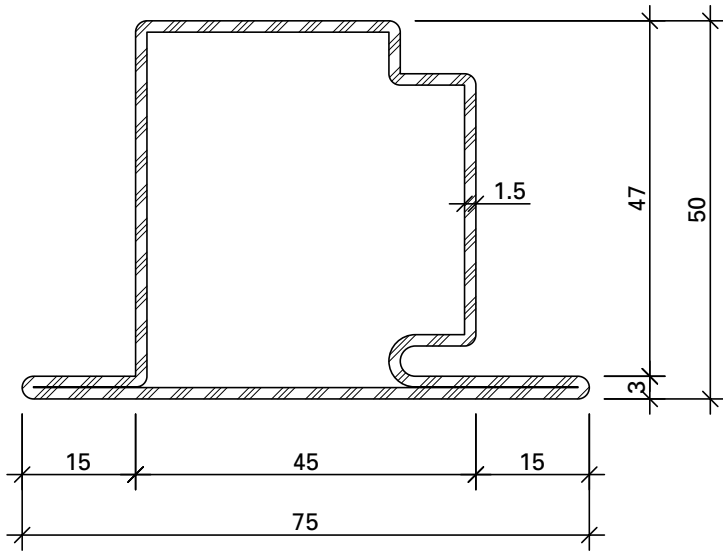

30.109

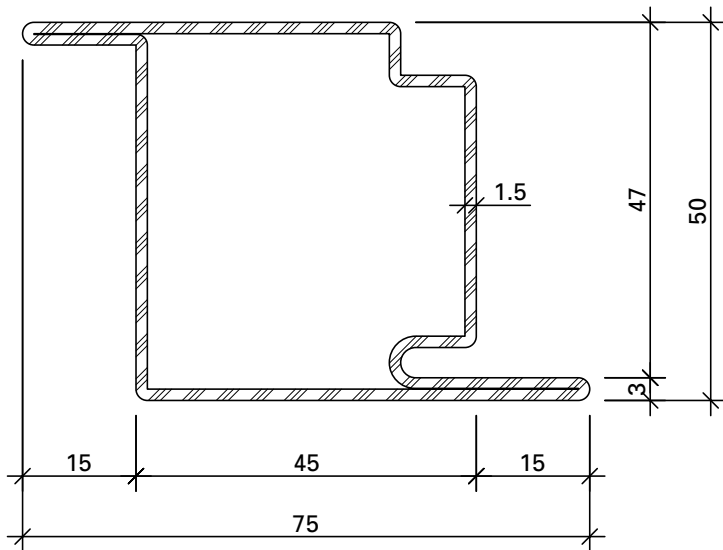

30.409

Werkstoffe

ohne Zusatz = blank
mit Z = bandverzinkter Stahl

Matériaux

sans supplément = brut
avec Z = bande d'acier zinguée

Materials

without addition = bright
with Z = strip galvanised steel

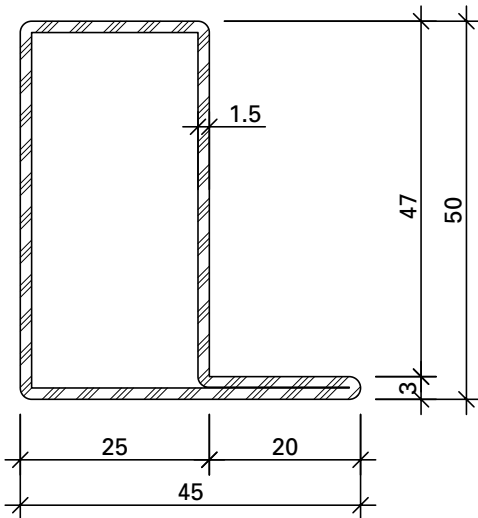

01.534
01.534 Z

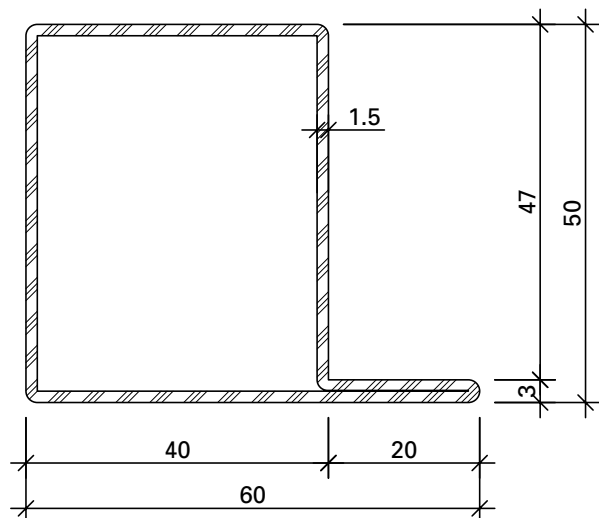

01.564
01.564 Z

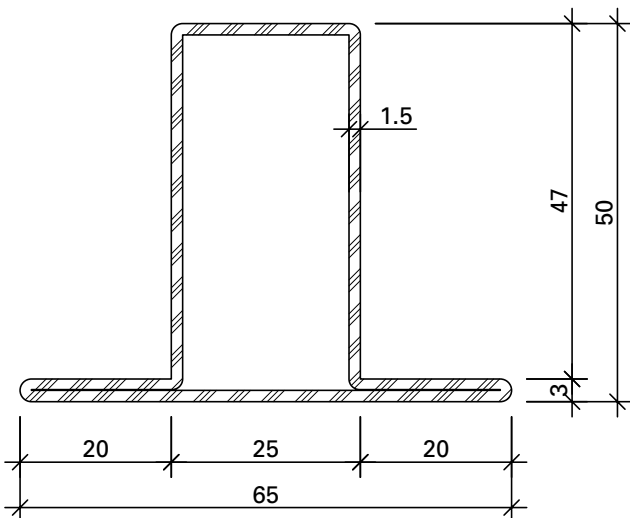

02.534
02.534 Z

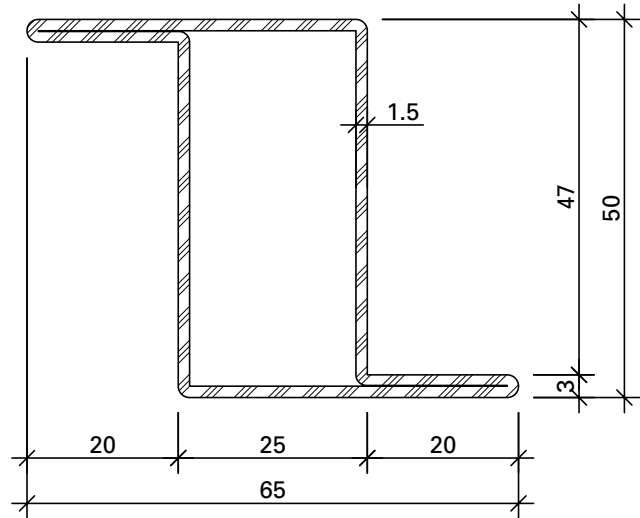

03.534
03.534 Z

Werkstoffe

ohne Zusatz = blank
mit Z = bandverzinkter Stahl

Matériaux

sans supplément = brut
avec Z = bande d'acier zinguée

Materials

without addition = bright
with Z = strip galvanised steel

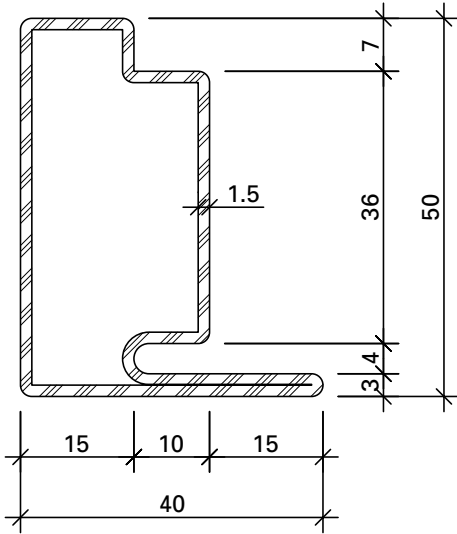

30.006
30.006 Z

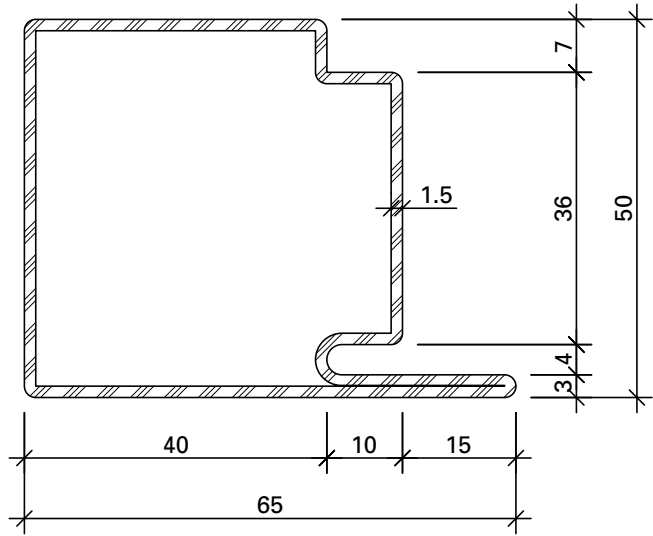

30.007
30.007 Z

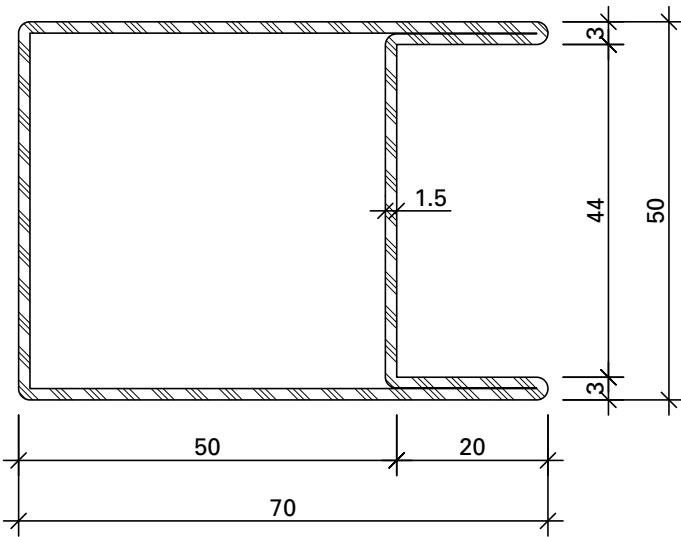

04.568
04.568 Z

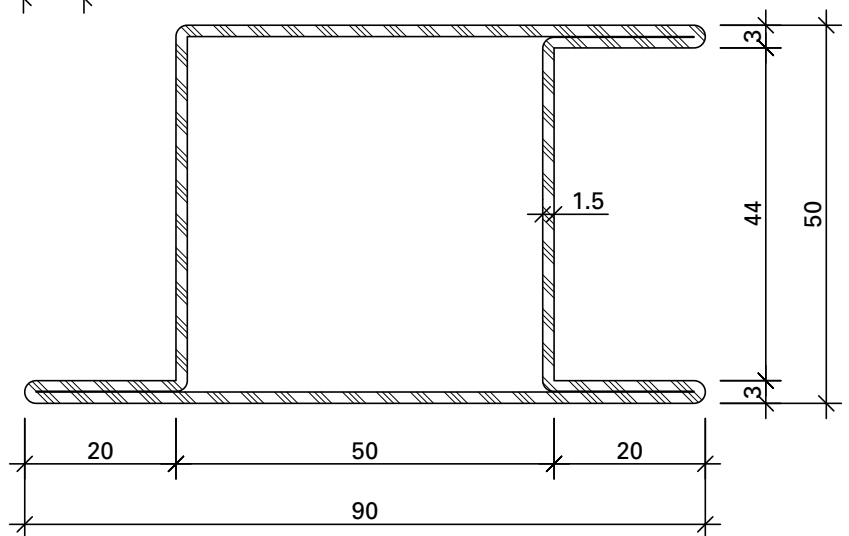

05.568
05.568 Z

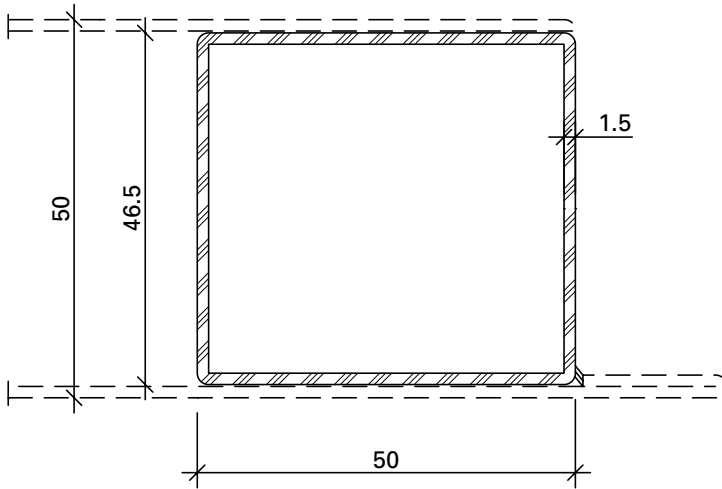

400.049 Z

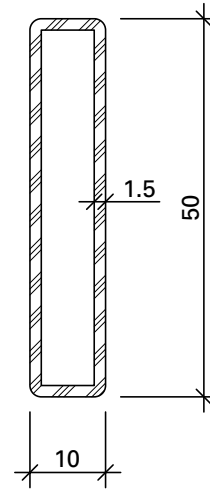

50x10x1,5*

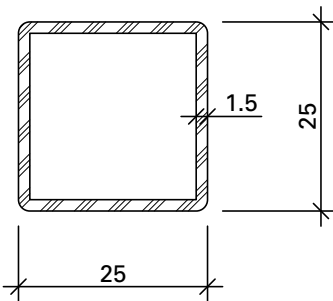

25x25x1,5*

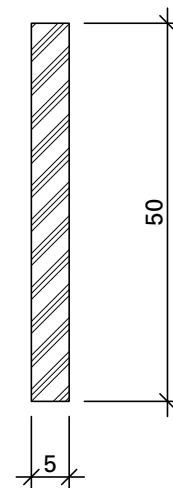

50x5*

* Durch Metallbauer
* Par le métallier
* By metal constructor

Artikelbibliothek
Bibliothèque des articles
Article library

DXF **DWG**

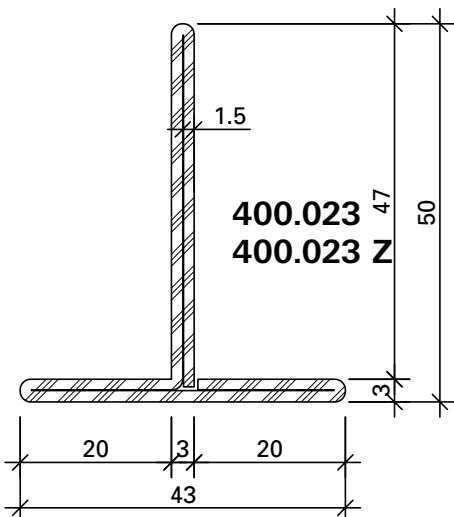
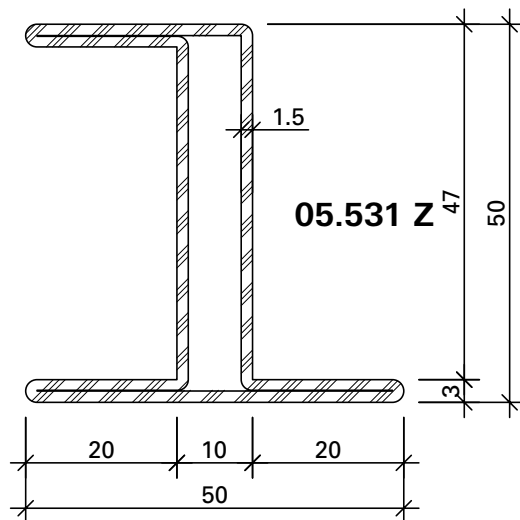
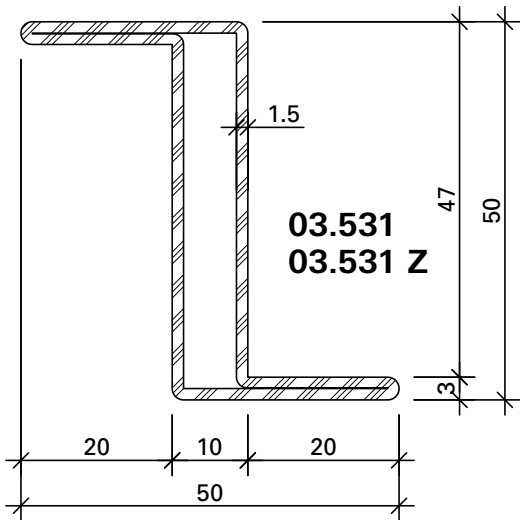
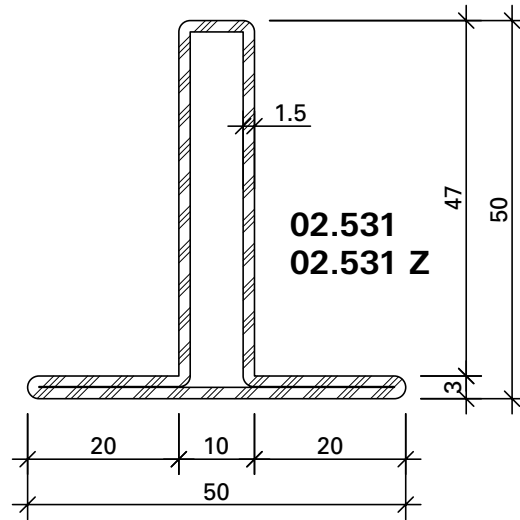
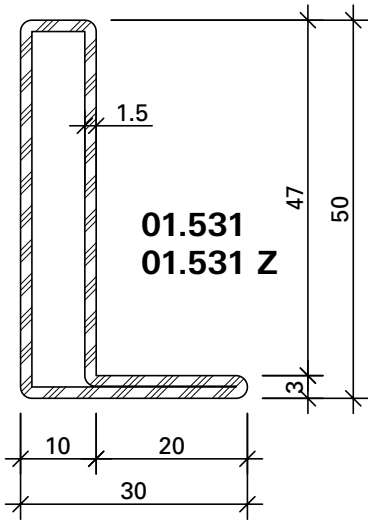

Artikelbibliothek
Bibliothèque des articles
Article library

DXF **DWG**

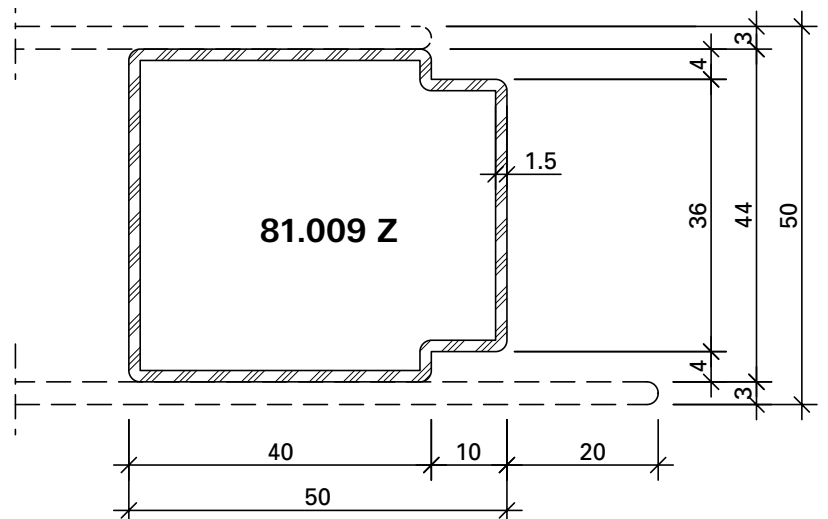
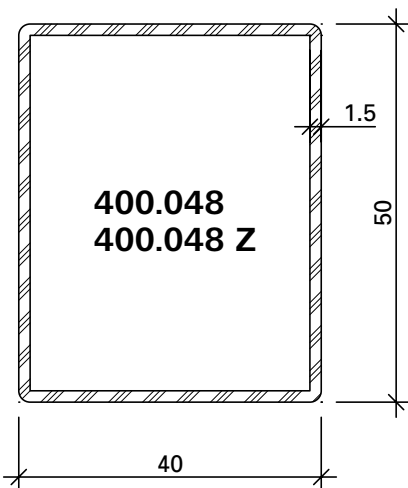
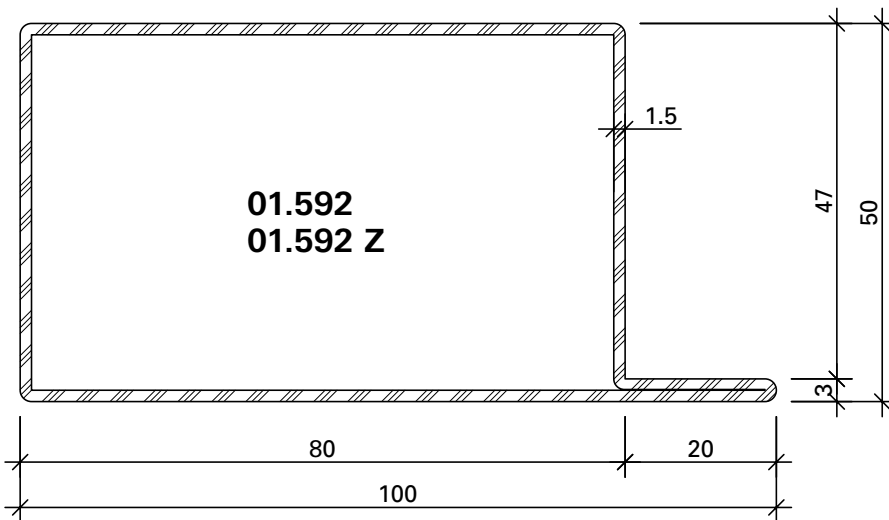
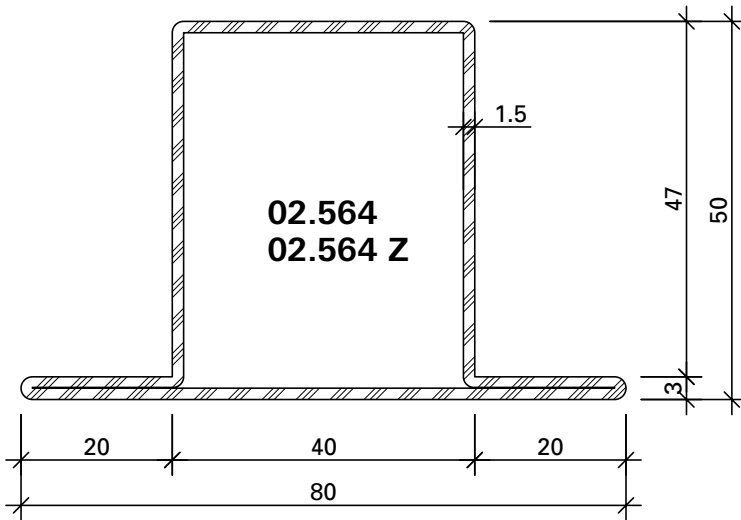

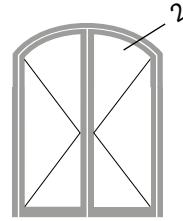
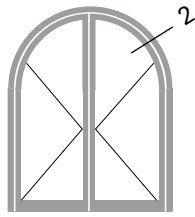
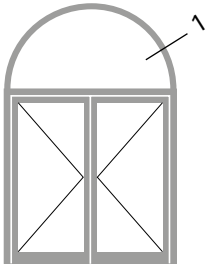

1.0

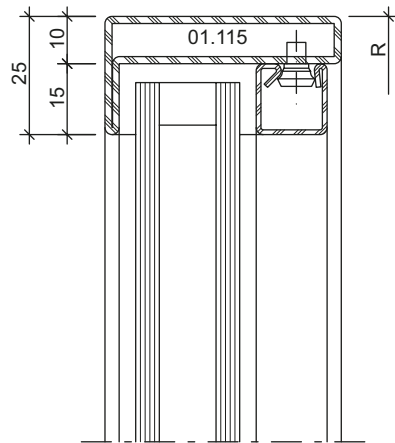

2.0

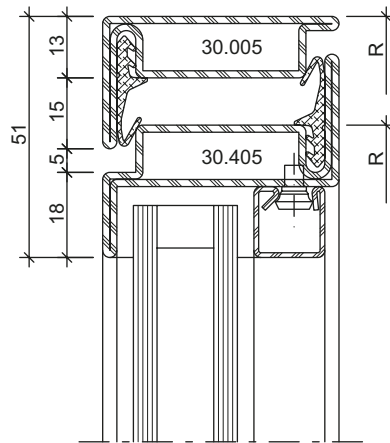

2.1

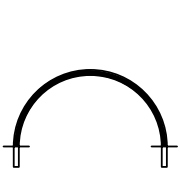
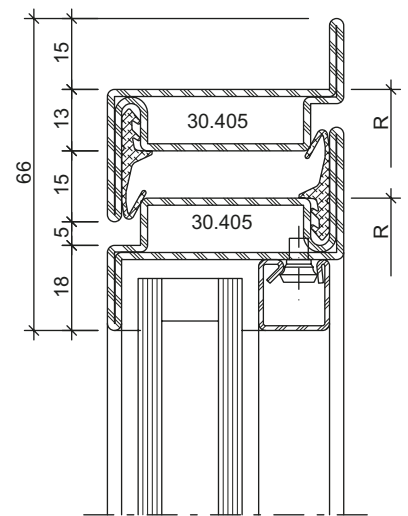

Halbrundbogen
 Arc semi-circulaire
 Semi-circular arch

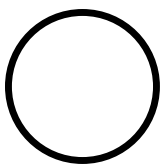

Rundbogen
 Arc en plein centre
 Round arch

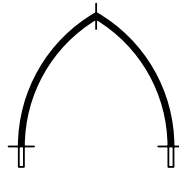

Spitzbogen
 Arc en ogive
 Gothic arch



Stichbogen
 Arc bombé
 Segmented arch



Korbbogen
 Anse de panier
 Oval arch

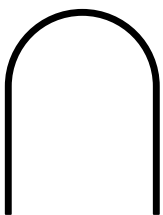

Halbrundbogen mit Schenkel
 Arc surhaussé prolongée
 Semi-circular arch with side extension

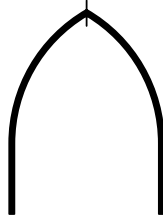

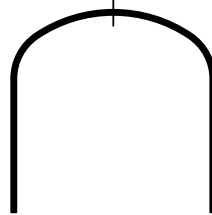

Spitzbogen mit Schenkel
 Arc en ogive prolongée
 Gothic arch with side extension







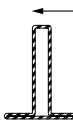
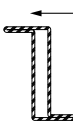

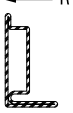
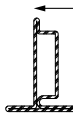
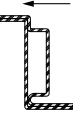

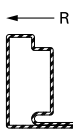
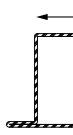
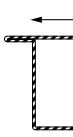
Korbbogen mit Schenkel
 Anse de panier prolongée
 Oval arch with side extension

Bogentüren
Portes cintrées
Arched doors

Jansen Art'15
 Jansen Art'15
 Jansen Art'15

| Profil Profilé Profile | Min. Radius Rayon min. Min. radius R | blank brut bright | verzinkt zinguées galvanised |
|---|---|-------------------------|------------------------------------|
|  | | mm | mm |
| 01.115 | 350 | | |
| 01.534 | 400 | 800 | |
| 01.564 | 650 | 1050 | |
|  | | | |
| 02.115 | 350 | | |
| 02.534 | 400 | 800 | |
|  | | | |
| 03.115 | 400 | | |
| 03.534 | 500 | 800 | |
|  | | | |
| 05.115 | 350 | | |
|  | | | |
| 30.005 | 350 | | |
|  | | | |
| 30.105 | 350 | | |
|  | | | |
| 30.405 | 400 | | |

| Profil Profilé Profile | Min. Radius Rayon min. Min. radius R | blank brut bright | verzinkt zinguées galvanised |
|---|---|-------------------------|------------------------------------|
|  | | mm | mm |
| 30.006 | 500 | 500 | |
| 30.007 | 550 | 550 | |
|  | | | |
| 30.109 | 800 | | |
|  | | | |
| 30.409 | 800 | | |
|  | | | |
| 04.568 | 850 | | |
|  | | | |
| 05.568 | 850 | 1250 | |
|  | | | |
| 400.048 | 1500 | 1500 | |
| 400.049 | 1500 | 1500 | |

| Profil Profilé Profile | Min. Radius Rayon min. Min. radius R |
|---|---|
|  | |
| 62.510 Z | 300 mm |
| 62.511 Z | 300 mm |
| 62.512 Z | 300 mm |
|  | |
| 402.190 Z | 300 mm |
| 402.191 Z | 300 mm |
| 402.192 Z | 300 mm |
|  | |
| 402.990 | 300 mm |
| 402.991 | 300 mm |
| 402.992 | 300 mm |
| Stahl-Glasleisten Parcloses en acier Steel glazing beads | Min. Radius Rayon min. Min. radius R |
|  | |
| 401.015 Z | 400 mm |

Die Radien-Angaben beziehen sich auf die langjährige Erfahrung und Fertigung im Hause Jansen.

Les rayons indiqués se fondent sur la longue expérience et la fabrication au sein de la maison Jansen.

The radii specifications are based on the many years of experience Jansen has in fabrication.

Glasleisten
 Parcloses
 Glazing beads

Jansen Art'15
 Jansen Art'15
 Jansen Art'15

Glasleisten aus bandverzinktem Stahl (Länge 6 m)
 Parcloses en bande d'acier zinguée (longueur 6 m)
 Glazing beads made of strip galvanised steel (length 6 m)

Aluminium-Glasleisten (Länge 6 m)
 Parcloses en aluminium (longueur 6 m)
 Aluminium glazing beads (length 6 m)

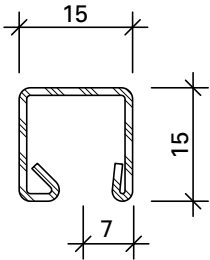

401.015 Z

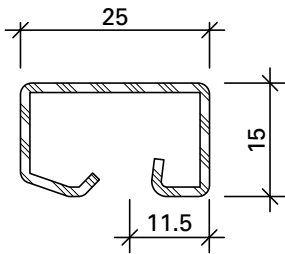

401.025 Z

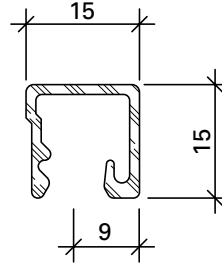

404.015

*Einbausituationen Glasleisten
 ab Seite 77 beachten
 Tenir compte des situations de
 montage des parcloses à partir
 de la page 77
 Observe installation situations for
 glazing beads from page 77*

Befestigungsknöpfe für Glasleisten

Boutons de fixation pour parcloses

Fastening studs for glazing beads



450.006

Befestigungsknopf

Stahl, SR1-Angriff, Länge 4.5 mm,
 Bohrdurchmesser 3.5 mm

VE = 100 Stück lose

450.006

Bouton de fixation

acier, empreinte SR1, longueur
 4.5 mm, diamètre de perçage
 3.5 mm

UV = 100 pièces

450.006

Fastening stud

steel, SR1 head, length 4.5 mm,
 hole diameter 3.5 mm

PU = 100 pieces



450.007

Befestigungsknopf

Stahl, PH-Angriff, Länge 10 mm,
 selbstbohrend

VE = 50 Magazine à 10 Knöpfe

450.007

Bouton de fixation

acier, empreinte PH, longueur
 10 mm, autoforeuse

UV = 50 magasins à 10 pièces

450.007

Fastening stud

steel, PH head, length 10 mm,
 self-drilling

PU = 50 magazines with 10 studs



450.008

Befestigungsknopf

Stahl, PH-Angriff, Länge 10 mm,
 selbstbohrend

VE = 400 Magazine à 10 Knöpfe

450.008

Bouton de fixation

acier, empreinte PH, longueur
 10 mm, autoforeuse

UV = 400 magasins à 10 pièces

450.008

Fastening stud

steel, PH head, length 10 mm,
 self-drilling

PU = 400 magazines with 10 studs



450.009

Befestigungsknopf

Stahl, PH-Angriff, Länge 10 mm,
 selbstbohrend

VE = 1000 Stück lose

450.009

Bouton de fixation

acier, empreinte PH, longueur
 10 mm, autoforeuse

UV = 1000 pièces

450.009

Fastening stud

steel, PH head, length 10 mm,
 self-drilling

PU = 1000 pieces



450.014

Befestigungsknopf

Stahl, PH-Angriff, Länge 8 mm,
 selbstbohrend

VE = 50 Magazine à 10 Knöpfe

450.014

Bouton de fixation

acier, empreinte PH, longueur
 8 mm, autoforeuse

UV = 50 magasins à 10 pièces

450.014

Fastening stud

steel, PH head, length 8 mm,
 self-drilling

PU = 50 magazines with 10 studs

Glasleisten
Parcloses
Glazing beads

Jansen Art'15
Jansen Art'15
Jansen Art'15

Aluminium-Glasleisten
(Länge 6 m)

Parcloses en aluminium
(longueur 6 m)

Aluminium glazing beads
(length 6 m)

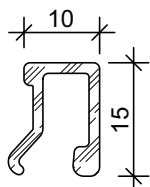

405.030

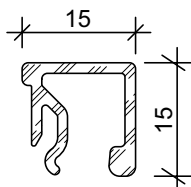

405.031

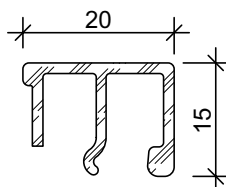

405.032

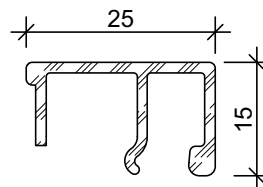

405.033

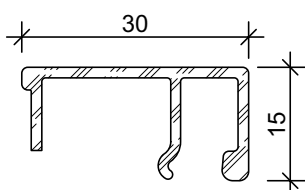

405.034

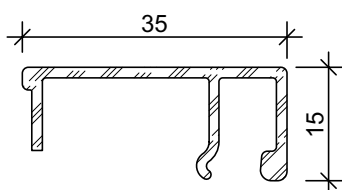

405.035

Einbausituationen Glasleisten ab Seite 77 beachten
Tenir compte des situations de montage des parcloses
à partir de la page 77
Observe installation situations for glazing beads from page 77

| Artikel-Nr. | G kg/m | U m ² /m | P m ² /m |
|-------------|-----------|------------------------|------------------------|
| 401.015 Z | 0,430 | 0,053 | 0,038 |
| 401.025 Z | 0,668 | 0,138 | 0,040 |
| 404.015 | 0,190 | 0,097 | 0,030 |

| Artikel-Nr. | G kg/m | U m ² /m | P m ² /m |
|-------------|-----------|------------------------|------------------------|
| 405.030 | 0,162 | 0,079 | 0,025 |
| 405.031 | 0,207 | 0,100 | 0,030 |
| 405.032 | 0,234 | 0,116 | 0,035 |
| 405.033 | 0,253 | 0,126 | 0,040 |
| 405.034 | 0,271 | 0,136 | 0,045 |
| 405.035 | 0,291 | 0,146 | 0,050 |

G = Gewicht
U = Abwicklung umlaufend
P = Polierabwicklung

G = Poids
U = Périmètre extérieur
P = Périmètre à polir

G = Weight
U = Circumferential development
P = Circumferential polishing

Befestigungsknöpfe für Glasleisten

Boutons de fixation pour parcloses

Fastening studs for glazing beads



450.015

Befestigungsknopf
Stahl, Torx-Angriff T15,
Länge 3.4 mm,
Bohrdurchmesser 3.5 mm
VE = 100 Stück lose

450.015

Bouton de fixation
acier, empreinte Torx T15,
longueur 3.4 mm, diamètre
de perçage 3.5 mm
UV = 100 pièces

450.015

Fastening stud
steel, Torx head T15,
length 3.4 mm,
hole diameter 3.5 mm
PU = 100 pieces



450.016

Befestigungsknopf
Stahl, Torx-Angriff T15,
Länge 8 mm, selbstbohrend
VE = 50 Magazine à 10 Knöpfe

450.016

Bouton de fixation
acier, empreinte Torx T15,
longueur 8 mm, autoforeuse
UV = 50 magasins à 10 pièces

450.016

Fastening stud
steel, Torx head T15,
length 8 mm, self-drilling
PU = 50 magazines with 10 studs



499.001

Befestigungsset
zum Versetzen der magazi-
nierten Befestigungs-Knöpfe
450.007/008/014

VE = 1 Set komplett inkl. Koffer
3 Kreuzschlitz-
Schraubklingen

499.001

**Machine à poser les boutons
de parcloses**
pour le déplacement des boutons
de fixations 450.007/008/014
emmagasinés

UV = 1 set complet, valise incl.
3 mèches cruciforme

499.001

Fastening set
for placing magazine fixing
studs 450.007/008/014

PU = 1 set complete, incl. case
3 Phillips screwdriver
blades



499.015

Befestigungsset
zum Versetzen der
magazinierten Befestigungs-
Knöpfe 450.016

VE = 1 Set komplett inkl. Koffer
3 Torx

499.015

**Machine à poser les boutons
de parcloses**
pour le déplacement des
boutons de fixations 450.016
emmagasinés

UV = 1 set complet, valise incl.
3 Torx 15

499.015

Fastening set
for placing magazine fixing
studs 450.016

PU = 1 set complete, incl. case
3 Torx 15



499.016

Magazinträger
für Befestigungsknöpfe 450.016,
als Austausch auf
Befestigungsset 499.001

VE = 1 Stück

499.016

Porte-magazine
pour boutons de fixations
450.016, comme remplacement
sur la machine à poser les
boutons de parclosé 499.001

UV = 1 pièce

499.016

Magazine case
for fixing studs 450.016,
as replacement on fixing kit
499.001

PU = 1 piece

**Winkelkontur-Stahl-Glasleisten
 (Länge ca. 6 m)**

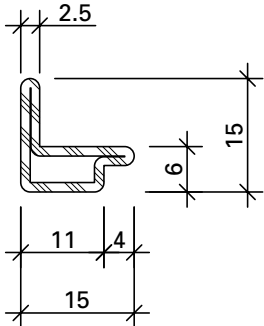

62.510 Z

mit Z = bandverzinkter Stahl

**Parcloses en acier à contour
 angulaire (longueur env. 6 m)**

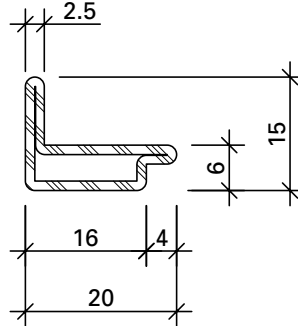

62.511 Z

avec Z = bande d'acier zinguée

**Angle contour steel glazing beads
 (length approx. 6 m)**

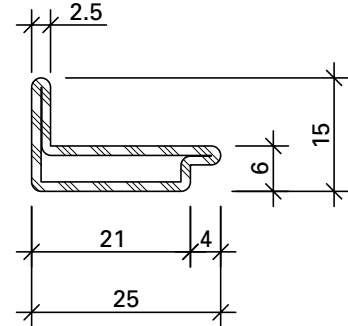

62.512 Z

with Z = strip galvanised steel

| Artikel-Nr. | G kg/m | U m ² /m |
|-----------------|-----------|------------------------|
| 62.510 Z | 0,510 | 0,056 |
| 62.511 Z | 0,610 | 0,066 |
| 62.512 Z | 0,710 | 0,076 |

G = Gewicht
 U = Abwicklung umlaufend

G = Poids
 U = Périmètre extérieur

G = Weight
 U = Circumferential development

*Einbausituationen Glasleisten
 ab Seite 77 beachten*

*Tenir compte des situations de montage
 des parcloses à partir de la page 77*

*Observe installation situations for
 glazing beads from page 77*



**557.168
 557.325** schwarz

Schraube M4x10
 Edelstahl, Torx-Angriff,
 zur Befestigung der Glasleisten
 Bohrdurchmesser 3,3 mm

VE = 100 Stück

**557.168
 557.325** noir

Vis M4x10
 acier Inox, empreinte Torx,
 pour fixer les parcloses
 Diamètre de perçage 3,3 mm

UV = 100 pièces

**557.168
 557.325** black

Screw M4x10
 stainless steel, Torx head,
 for fixing the glazing beads
 Hole diameter 3,3 mm

PU = 100 pieces



**557.166
 557.323** schwarz

Schraube M4x10
 Edelstahl, Torx-Angriff,
 zur Befestigung der Glasleisten
 Bohrdurchmesser 3,3 mm

VE = 100 Stück

**557.166
 557.323** noir

Vis M4x10
 acier Inox, empreinte Torx,
 pour fixer les parcloses
 Diamètre de perçage 3,3 mm

UV = 100 pièces

**557.166
 557.323** black

Screw M4x10
 stainless steel, Torx head,
 for fixing the glazing beads
 Hole diameter 3,3 mm

PU = 100 pieces

Glasleisten
Parcloses
Glazing beads

Jansen Art'15
 Jansen Art'15
 Jansen Art'15

Winkel-Stahl-Glasleisten
(Länge 6 m)

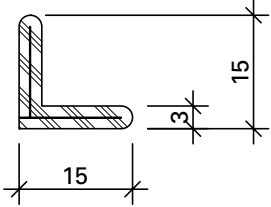

402.190 Z
402.590*
402.990**

* = Edelstahl 1.4401 (AISI 316)
 blank
 ** = Corten

Parcloses en acier angulaire
(longueur 6 m)

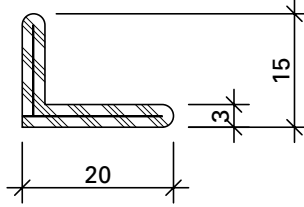

402.191 Z
402.591*
402.991**

* = Acier Inox 1.4401 (AISI 316)
 brut
 ** = Corten

Angle steel glazing beads
(length 6 m)

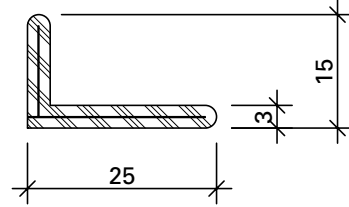

402.192 Z
402.592*
402.992**

* = Stainless steel 1.4401 (AISI 316)
 bright
 ** = Corten

Einbausituationen Glasleisten ab Seite 77 beachten

Tenir compte des situations de montage des parcloses à partir de la page 77

Observe installation situations for glazing beads from page 77

| Artikel-Nr. | G kg/m | U m ² /m | P m ² /m |
|------------------|-----------|------------------------|------------------------|
| 402.190 Z | 0,616 | 0,063 | 0,033 |
| 402.191 Z | 0,734 | 0,073 | 0,038 |
| 402.192 Z | 0,852 | 0,083 | 0,043 |

| Artikel-Nr. | G kg/m | P m ² /m |
|----------------|-----------|------------------------|
| 402.590 | 0,625 | 0,033 |
| 402.591 | 0,744 | 0,038 |
| 402.592 | 0,864 | 0,043 |

| Artikel-Nr. | G kg/m | U m ² /m |
|----------------|-----------|------------------------|
| 402.990 | 0,616 | 0,063 |
| 402.991 | 0,734 | 0,073 |
| 402.992 | 0,852 | 0,083 |

G = Gewicht
 U = Abwicklung umlaufend
 P = Polierabwicklung

G = Poids
 U = Périmètre extérieur
 P = Périmètre à polir

G = Weight
 U = Circumferential development
 P = Circumferential polishing



557.167
557.324 schwarz

Schraube M4x8
 Edelstahl, Torx-Angriff,
 zur Befestigung der Glasleisten

Bohrdurchmesser 3,3 mm

VE = 100 Stück

557.167
557.324 noir

Vis M4x8
 acier Inox, empreinte Torx,
 pour fixer les parcloses

Diamètre de perçage 3,3 mm

UV = 100 pièces

557.167
557.324 black

Screw M4x8
 stainless steel, Torx head,
 for fixing the glazing beads

Hole diameter 3,3 mm

PU = 100 pieces



557.165
557.322 schwarz

Schraube M4x8
 Edelstahl, Torx-Angriff,
 zur Befestigung der Glasleisten

Bohrdurchmesser 3,3 mm

VE = 100 Stück

557.165
557.322 noir

Vis M4x8
 acier Inox, empreinte Torx,
 pour fixer les parcloses

Diamètre de perçage 3,3 mm

UV = 100 pièces

557.165
557.322 black

Screw M4x8
 stainless steel, Torx head,
 for fixing the glazing beads

Hole diameter 3,3 mm

PU = 100 pieces

Glasleisten
 Parcloses
 Glazing beads

Jansen Art'15
 Jansen Art'15
 Jansen Art'15

Aluminium-Glasleisten
 (Länge 6 m)

Parcloses en aluminium
 (longueur 6 m)

Aluminium glazing beads
 (length 6 m)

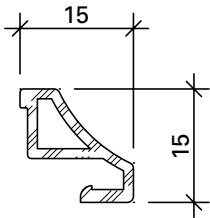

406.930

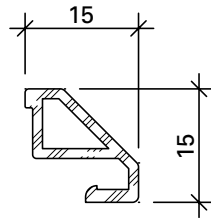

406.931

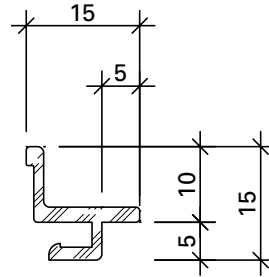

406.932

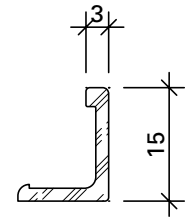

406.933

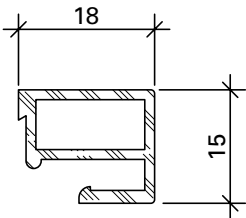

405.018

| Artikel-Nr. | G kg/m | U m ² /m | P m ² /m |
|-------------|-----------|------------------------|------------------------|
| 406.930 | 0,165 | 0,063 | 0,026 |
| 406.931 | 0,170 | 0,063 | 0,024 |
| 406.932 | 0,152 | 0,068 | 0,035 |
| 406.933 | 0,124 | 0,055 | 0,018 |
| 405.018 | 0,244 | 0,086 | 0,033 |

G = Gewicht
 U = Abwicklung umlaufend
 P = Polierabwicklung

G = Poids
 U = Périmètre extérieur
 P = Périmètre à polir

G = Weight
 U = Circumferential development
 P = Circumferential polishing

Einbausituationen Glasleisten ab Seite 77 beachten
 Tenir compte des situations de montage des parcloses à partir de la page 77
 Observe installation situations for glazing beads from page 77



450.022

Befestigungsfeder
 Edelstahl, inkl. Schraube,
 Bohrdurchmesser \varnothing 3,5 mm
 VE = 100 Stück

450.022

Ressort de fixation
 acier Inox, vis inclus,
 diamètre de perçage \varnothing 3,5 mm
 UV = 100 pièces

450.022

Fixing spring
 stainless steel, incl. screw,
 hole diameter \varnothing 3,5 mm
 PU = 100 pieces



450.020

Befestigungsknopf
 Kunststoff
 VE = 100 Stück

450.020

Bouton de fixation
 matière plastique
 UV = 100 pièces

450.020

Stud
 plastic
 PU = 100 pieces



450.021

Schraube M3x12
 Stahl verzinkt,
 Bohrdurchmesser \varnothing 2,8 mm
 VE = 100 Stück

450.021



Vis M3x12
 acier zingué,
 diamètre de perçage \varnothing 2,8 mm
 UV = 100 pièces

450.021

Screw M3x12
 galvanised steel,
 hole diameter \varnothing 2,8 mm
 PU = 100 pieces

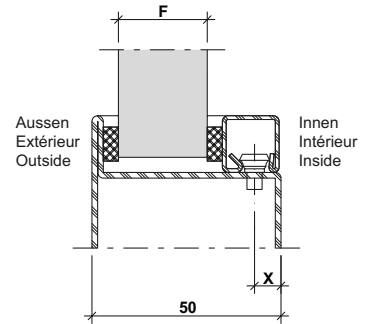
Verglasungstabelle mit Distanzband (Nassverglasung)
 Tableau de vitrage avec bande d'écartement (vitrage à mastic)
 Glazing table with packing tape (glazing with sealing)



| Fugenbreite (mm) Largeur du joint (mm) Width of joint (mm) | Aussen Extérieur Outside | Innen Intérieur Inside | Aussen Extérieur Outside | Innen Intérieur Inside | Aussen Extérieur Outside | Innen Intérieur Inside | Aussen Extérieur Outside | Innen Intérieur Inside | Aussen Extérieur Outside | Innen Intérieur Inside | X | Glasleisten Parcloses Glazing beads |
|--|--------------------------------|------------------------------|--------------------------------|------------------------------|--------------------------------|------------------------------|--------------------------------|------------------------------|--------------------------------|------------------------------|------|---|
| | | 450.032 450.062 | 450.032 450.062 | 450.032 450.062 | 450.031 450.061 | 450.031 450.061 | 450.031 450.061 | 450.031 450.061 | 450.031 450.061 | 450.030 450.060 | | |
| | 6 | 6 | 6 | 5 | 5 | 5 | 5 | 5 | 4 | 4 | 4 | |
| | 10 | | 11 | | 12 | | 13 | | 14 | | 11.5 |  401.025 Z |
| | 20 | | 21 | | 22 | | 23 | | 24 | | 7 |  401.015 Z |

Einbausituationen Glasleisten
 ab Seite 77 beachten

Tenir compte des situations de montage
 des parcloses à partir de la page 77

Observe installation situations for
 glazing beads from page 77

Hinweise Verglasungsvarianten
 siehe Seite 39

Remarques variantes de vitrage
 voir page 39

Notices alternative glazings
 see page 39

Verglasungstabelle mit Distanzband (Nassverglasung)
 Tableau de vitrage avec bande d'écartement (vitrage à mastic)
 Glazing table with packing tape (glazing with sealing)

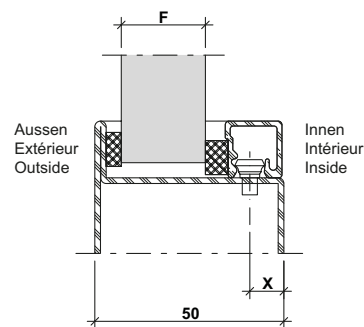

| Fugenbreite (mm) Largeur du joint (mm) Width of joint (mm) | Aussen Extérieur Outside | Innen Intérieur Inside | Aussen Extérieur Outside | Innen Intérieur Inside | Aussen Extérieur Outside | Innen Intérieur Inside | Aussen Extérieur Outside | Innen Intérieur Inside | Aussen Extérieur Outside | Innen Intérieur Inside | X | Glasleisten Parcloses Glazing beads |
|--|--------------------------------|------------------------------|--------------------------------|------------------------------|--------------------------------|------------------------------|--------------------------------|------------------------------|--------------------------------|------------------------------|---|---|
| | 450.032 | 450.034 | 450.031 | 450.034 | 450.032 | 450.034 | 450.031 | 450.032 | 450.030 | 450.032 | | |
| | 450.062 | 450.064 | 450.061 | 450.064 | 450.062 | 450.064 | 450.061 | 450.062 | 450.060 | 450.062 | | |
| | 6 | 6 | 6 | 5 | 5 | 5 | 5 | 4 | 4 | 4 | | |
| | 20 | | 21 | | 22 | | 23 | | 24 | | 9 |  404.015 |

Einbausituationen Glasleisten
 ab Seite 77 beachten

Tenir compte des situations de montage
 des parcloses à partir de la page 77

Observe installation situations for
 glazing beads from page 77

Hinweise Verglasungsvarianten
 siehe Seite 39

Remarques variantes de vitrage
 voir page 39

Notices alternative glazings
 see page 39

Verglasungsvarianten
 Variantes de vitrage
 Alternative glazing

Jansen Art'15
 Jansen Art'15
 Jansen Art'15

Verglasungstabelle mit Distanzband
 (Nassverglasung)

Tableau de vitrage avec bande d'écartement
 (Vitrage à mastic)

Glazing table with distance strip
 (Glazing with sealing)

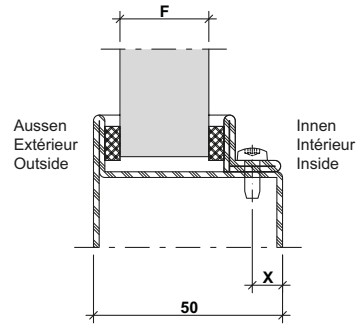

| Fugenbreite (mm) Largeur du joint (mm) Width of joint (mm) | Aussen Extérieur Outside | Innen Intérieur Inside | Aussen Extérieur Outside | Innen Intérieur Inside | Aussen Extérieur Outside | Innen Intérieur Inside | Aussen Extérieur Outside | Innen Intérieur Inside | Aussen Extérieur Outside | Innen Intérieur Inside | X | Glasleisten Parcloses Glazing beads | |
|--|--------------------------------|------------------------------|--------------------------------|------------------------------|--------------------------------|------------------------------|--------------------------------|------------------------------|--------------------------------|------------------------------|---|---|--------------------|
| | 450.032 450.062 | 450.032 450.062 | 450.032 450.062 | 450.031 450.061 | 450.031 450.061 | 450.031 450.061 | 450.031 450.061 | 450.031 450.061 | 450.030 450.060 | 450.030 450.060 | | | 450.030 450.060 |
| | 6 | 6 | 6 | 5 | 5 | 5 | 5 | 5 | 4 | 4 | | | 4 |
| Verglasung F Vitrage F Glazing F | 10 | | 11 | | 12 | | 13 | | 14 | | 8 | 402.192 402.592 402.992 | |
| | 15 | | 16 | | 17 | | 18 | | 19 | | 8 | 402.191 402.591 402.991 | |
| | 20 | | 21 | | 22 | | 23 | | 24 | | 8 | 402.190 402.590 402.990 | |

Einbausituationen Glasleisten
 ab Seite 77 beachten

Tenir compte des situations de montage
 des parcloses à partir de la page 77

Observe installation situations for
 glazing beads from page 77

Hinweise Verglasungsvarianten
 siehe Seite 39

Remarques variantes de vitrage
 voir page 39

Notices alternative glazings
 see page 39

Verglasungstabelle mit Distanzband
 (Nassverglasung)

Tableau de vitrage avec bande d'écartement
 (Vitrage à mastic)

Glazing table with distance strip
 (Glazing with sealing)

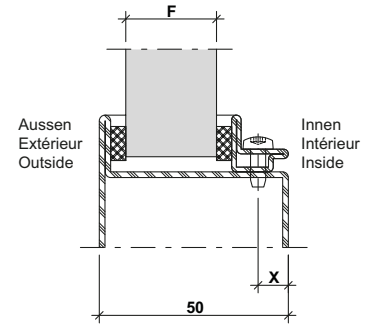

| Fugenbreite (mm) Largeur du joint (mm) Width of joint (mm) | Aussen Extérieur Outside | Innen Intérieur Inside | Aussen Extérieur Outside | Innen Intérieur Inside | Aussen Extérieur Outside | Innen Intérieur Inside | Aussen Extérieur Outside | Innen Intérieur Inside | Aussen Extérieur Outside | Innen Intérieur Inside | X | Glasleisten Parcloses Glazing beads | |
|--|--------------------------------|------------------------------|--------------------------------|------------------------------|--------------------------------|------------------------------|--------------------------------|------------------------------|--------------------------------|------------------------------|---|---|--------------------|
| | 450.032 450.062 | 450.032 450.062 | 450.032 450.062 | 450.031 450.061 | 450.031 450.061 | 450.031 450.061 | 450.031 450.061 | 450.031 450.061 | 450.030 450.060 | 450.030 450.060 | | | 450.030 450.060 |
| | 6 | 6 | 6 | 5 | 5 | 5 | 5 | 4 | 4 | 4 | | | |
| Verglasung F Vitrage F Glazing F | 10 | | 11 | | 12 | | 13 | | 14 | | 8 | 25 62.512 | |
| | 15 | | 16 | | 17 | | 18 | | 19 | | 8 | 20 62.511 | |
| | 20 | | 21 | | 22 | | 23 | | 24 | | 8 | 15 62.510 | |

Einbausituationen Glasleisten
 ab Seite 77 beachten

Tenir compte des situations de montage
 des parcloses à partir de la page 77

Observe installation situations for
 glazing beads from page 77

Hinweise Verglasungsvarianten
 siehe Seite 39

Remarques variantes de vitrage
 voir page 39

Notices alternative glazings
 see page 39

Verglasungstabelle mit Distanzband
 (Nassverglasung)

Tableau de vitrage avec bande d'écartement
 (Vitrage à mastic)

Glazing table with distance strip
 (Glazing with sealing)

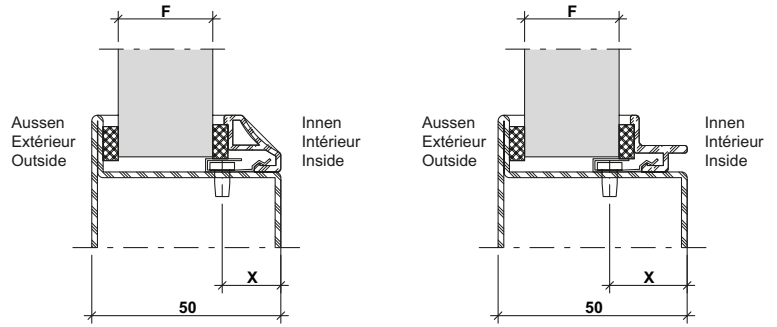

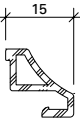
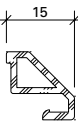
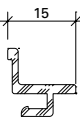
| Fugenbreite (mm) Largeur du joint (mm) Width of joint (mm) | Aussen Extér. Outside | Innen Intér. Inside | Aussen Extér. Outside | Innen Intér. Inside | Aussen Extér. Outside | Innen Intér. Inside | Aussen Extér. Outside | Innen Intér. Inside | Aussen Extér. Outside | Innen Intér. Inside | Aussen Extér. Outside | Innen Intér. Inside | X | Glas- leisten Parcloses Glazing beads |
|--|-----------------------------|---------------------------|-----------------------------|---------------------------|-----------------------------|---------------------------|-----------------------------|---------------------------|-----------------------------|---------------------------|-----------------------------|---------------------------|---------------|---|
| | | 450.032 450.062 | 450.034 450.064 | 450.032 450.062 | 450.032 450.062 | 450.031 450.061 | 450.032 450.062 | 450.031 450.061 | 450.031 450.061 | 450.030 450.060 | 450.031 450.061 | 450.030 450.060 | | |
| | 6 | 7 | 6 | 5 | 5 | 5 | 5 | 4 | 4 | 4 | 4 | 3 | | |
| Verglasung F Vitrage F Glazing F | 19 | | 21 | | 22 | | 23 | | 24 | | 25 | | 15.5 20.5* |  406.930  406.931  406.932* |

Einbausituationen Glasleisten
 ab Seite 77 beachten

Tenir compte des situations de montage
 des parcloses à partir de la page 77

Observe installation situations for
 glazing beads from page 77

Hinweise Verglasungsvarianten
 siehe Seite 39

Remarques variantes de vitrage
 voir page 39

Notices alternative glazings
 see page 39

Verglasungstabelle mit Distanzband
 (Nassverglasung)

Tableau de vitrage avec bande d'écartement
 (Vitrage à mastic)

Glazing table with distance strip
 (Glazing with sealing)

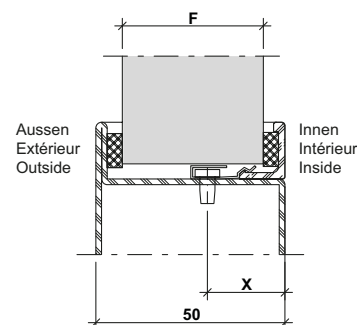

| Fugenbreite (mm) Largeur du joint (mm) Width of joint (mm) | Aussen Extér. Outside | Innen Intér. Inside | Aussen Extér. Outside | Innen Intér. Inside | Aussen Extér. Outside | Innen Intér. Inside | Aussen Extér. Outside | Innen Intér. Inside | Aussen Extér. Outside | Innen Intér. Inside | Aussen Extér. Outside | Innen Intér. Inside | X | Glasleisten Parcloles Glazing beads |
|--|-----------------------------|---------------------------|-----------------------------|---------------------------|-----------------------------|---------------------------|-----------------------------|---------------------------|-----------------------------|---------------------------|-----------------------------|---------------------------|------|--|
| | | 450.032 450.062 | 450.034 450.064 | 450.032 450.062 | 450.032 450.062 | 450.031 450.061 | 450.032 450.062 | 450.031 450.061 | 450.031 450.061 | 450.030 450.060 | 450.031 450.061 | 450.030 450.060 | | |
| | 6 | 7 | 6 | 5 | 5 | 5 | 5 | 4 | 4 | 4 | 4 | 3 | | |
| Verglasung F Vitrage F Glazing F | 31 | | 33 | | 34 | | 35 | | 36 | | 37 | | 20.5 | 406.933 |

Glasbestellung

Glaslieferanten auf die minimale Einstandtiefe hinweisen. Randverbund möglichst klein.

Die Größen der Isoliergläser sind wie folgt zu tolerieren:
 Breite und Höhe +0/-2 mm.

Commande de vitrage

Signaler la profondeur de prise en feuillure minimale aux fournisseurs de vitrage. Scellement le plus petit possible.

La tolérance relative aux verres isolants est la suivante:
 largeur et hauteur +0/-2 mm.

Glass order

Advise the glass supplier of the minimum edge cover depth. Edge seal as small as possible.

The following size tolerances for the insulating glass are to be permitted:
 +0/-2 mm in height and width.

*Einbausituationen Glasleisten
 ab Seite 77 beachten*

*Tenir compte des situations de montage
 des parcloles à partir de la page 77*

*Observe installation situations for
 glazing beads from page 77*

**Hinweise Verglasungsvarianten
 siehe Seite 39**

**Remarques variantes de vitrage
 voir page 39**

**Notices alternative glazings
 see page 39**

Verglasungstabelle mit Distanzband
(Nassverglasung)

Tableau de vitrage avec bande d'écartement
(Vitrage à mastic)

Glazing table with distance strip
(Glazing with sealing)

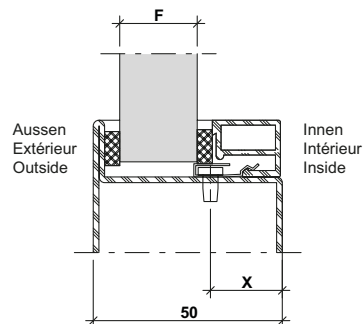

| Fugenbreite (mm) Largeur du joint (mm) Width of joint (mm) | Aussen Extér. Outside | Innen Intér. Inside | Aussen Extér. Outside | Innen Intér. Inside | Aussen Extér. Outside | Innen Intér. Inside | Aussen Extér. Outside | Innen Intér. Inside | Aussen Extér. Outside | Innen Intér. Inside | Aussen Extér. Outside | Innen Intér. Inside | X | Glasleisten Parcloses Glazing beads |
|--|-----------------------------|---------------------------|-----------------------------|---------------------------|-----------------------------|---------------------------|-----------------------------|---------------------------|-----------------------------|---------------------------|-----------------------------|---------------------------|----|--|
| | | 450.032 450.062 | 450.034 450.064 | 450.032 450.062 | 450.032 450.062 | 450.031 450.061 | 450.032 450.062 | 450.031 450.061 | 450.031 450.061 | 450.030 450.060 | 450.031 450.061 | 450.030 450.060 | | |
| | 6 | 7 | 6 | 5 | 5 | 5 | 5 | 4 | 4 | 4 | 4 | 3 | | |
| Verglasung F Vitrage F Glazing F | 17 | | 18 | | 19 | | 20 | | 21 | | 22 | | 19 | 405.018 |

Glasbestellung

Glaslieferanten auf die minimale Einstandtiefe hinweisen. Randverbund möglichst klein.

Die Größen der Isoliergläser sind wie folgt zu tolerieren: Breite und Höhe +0/-2 mm.

Commande de vitrage

Signaler la profondeur de prise en feuillure minimale aux fournisseurs de vitrage. Scellement le plus petit possible.

La tolérance relative aux verres isolants est la suivante: largeur et hauteur +0/-2 mm.

Glass order

Advise the glass supplier of the minimum edge cover depth. Edge seal as small as possible.

The following size tolerances for the insulating glass are to be permitted: +0/-2 mm in height and width.

Einbausituationen Glasleisten ab Seite 77 beachten

Tenir compte des situations de montage des parcloses à partir de la page 77

Observe installation situations for glazing beads from page 77

Hinweise Verglasungsvarianten siehe Seite 36

Remarques variantes de vitrage voir page 39

Notices alternative glazings see page 39

Verglasungstabelle mit Distanzband
 (Nassverglasung)

Tableau de vitrage avec bande d'écartement
 (vitrage à mastic)

Glazing table with spacing tape
 (glazing with sealing)

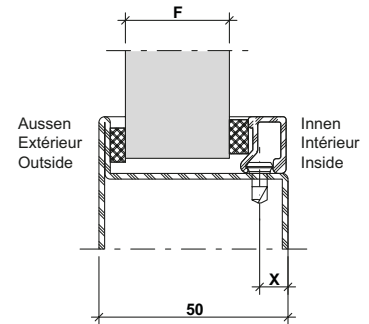

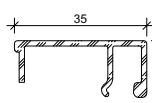
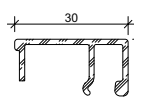
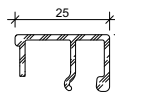
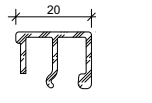
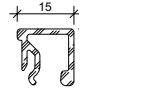
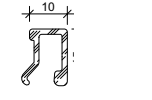
| Fugenbreite (mm) Largeur du joint (mm) Width of joint (mm) | Aussen Extér. Outside | Innen Intér. Inside | Aussen Extér. Outside | Innen Intér. Inside | Aussen Extér. Outside | Innen Intér. Inside | Aussen Extér. Outside | Innen Intér. Inside | Aussen Extér. Outside | Innen Intér. Inside | X | Glasleisten Parcloses Glazing beads |
|--|-----------------------------|---------------------------|-----------------------------|---------------------------|-----------------------------|---------------------------|-----------------------------|---------------------------|-----------------------------|---------------------------|-----|---|
| | 450.031 | 450.034 | 450.032 | 450.032 | 450.031 | 450.032 | 450.031 | 450.031 | 450.030 | 450.031 | | |
| | 450.061 | 450.064 | 450.062 | 450.062 | 450.061 | 450.062 | 450.061 | 450.061 | 450.060 | 450.061 | | |
| | 5 | 7 | 6 | 5 | 5 | 5 | 5 | 4 | 4 | 4 | | |
| Verglasung F Vitrage F Glazing F | | | | | | | | | 4 | | 7.5 |  405.035 |
| | | 5 | 6 | 7 | 8 | 9 | | | | | 7.5 |  405.034 |
| | | 10 | 11 | 12 | 13 | 14 | | | | | 7.5 |  405.033 |
| | | 15 | 16 | 17 | 18 | 19 | | | | | 7.5 |  405.032 |
| | | 20 | 21 | 22 | 23 | 24 | | | | | 7.5 |  405.031 |
| | | 25 | 26 | 27 | 28 | 29 | | | | | 7.5 |  405.030 |

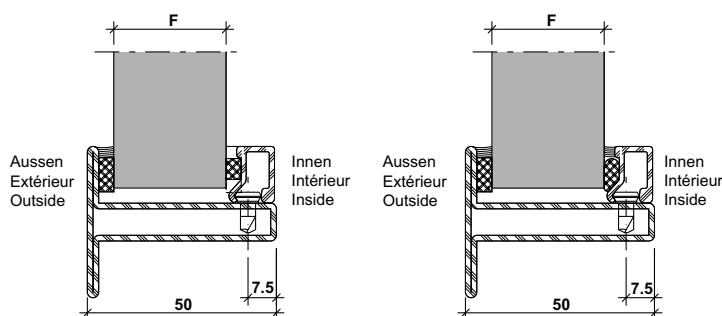

Band innen in der Breite zuschneiden
 oder Rundschnur verwenden.
 Couper la bande à l'intérieur à la bonne
 largeur ou utiliser une corde ronde.
 Cut along the width of the tape on the
 inside or use gasket cord.

Verglasungstabelle Trockenverglasung
 Tableau de vitrage à sec
 Glazing table dry glazing

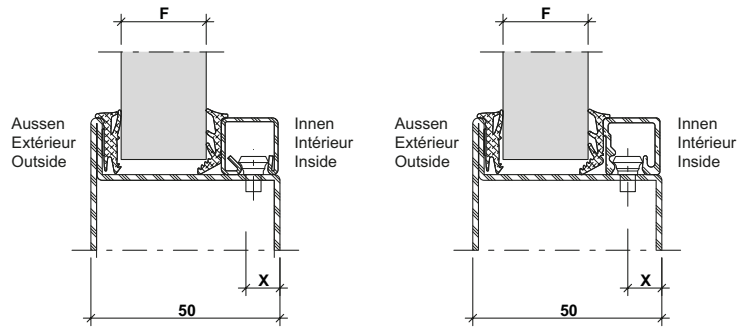

| Dichtung Joint Weatherstrip | Aussen Extérieur Outside | Innen Intérieur Inside | | | | | | X | Glasleisten Parcloses Glazing beads |
|--|--------------------------------|------------------------------|-------------|-------------|-------------|-------------|------|---------------|---|
| | 455.608 | 455.610 | 455.610 | 455.610 | 455.609 | 455.609 | | | |
| Verglasung F Vitrage F Glazing F | 5 | 9 | 10 | 11 | 12 | 13 | 11.5 | 401.025 Z | |
| | | 19 | 20 | 21 | 22 | 23 | 7 | 401.015 Z | |
| | | | | | | | 9 | 404.015 | |

Einbausituationen Glasleisten
 ab Seite 77 beachten

Tenir compte des situations de montage
 des parcloses à partir de la page 77

Observe installation situations for
 glazing beads from page 77









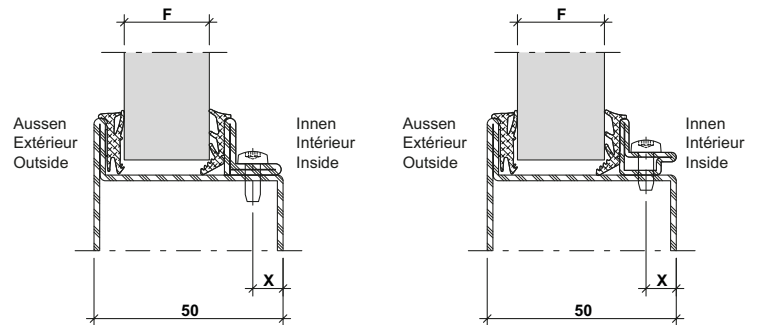



Hinweise Verglasungsvarianten
 siehe Seite 39

Remarques variantes de vitrage
 voir page 39

Notices alternative glazings
 see page 39

Verglasungstabelle Trockenverglasung
 Tableau de vitrage à sec
 Glazing table dry glazing



| Dichtung Joint Weatherstrip | Aussen Extérieur Outside | Innen Intérieur Inside | | | | | | X | Glasleisten Parcloses Glazing beads | |
|--|--|--|--|--|--|--|--|---|---|--|
| | 455.608  | 455.610  | 455.610  | 455.610  | 455.609  | 455.609  | 455.609  | | | |
| Verglasung F Vitrage F Glazing F | 5 | 9 | 10 | 11 | 12 | 13 | 8 |  62.512 |  402.192 402.592 402.992 | |
| | | 14 | 15 | 16 | 17 | 18 | 8 |  62.511 |  402.191 402.591 402.991 | |
| | | 19 | 20 | 21 | 22 | 23 | 8 |  62.510 |  402.190 402.590 402.990 | |

Einbausituationen Glasleisten
 ab Seite 77 beachten

Tenir compte des situations de montage
 des parcloses à partir de la page 77

Observe installation situations for
 glazing beads from page 77



Hinweise Verglasungsvarianten
 siehe Seite 39

Remarques variantes de vitrage
 voir page 39

Notices alternative glazings
 see page 39

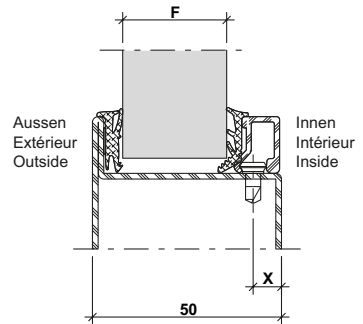
Verglasungstabelle Trockenverglasung
 Tableau de vitrage à sec
 Glazing table dry glazing

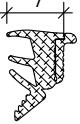
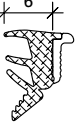
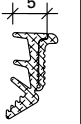
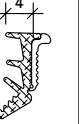
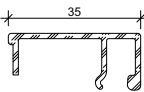
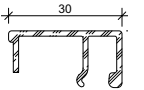
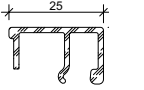
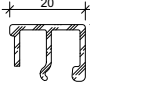
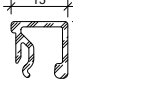
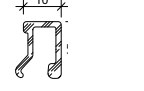

| Dichtung Joint Weatherstrip | Aussen Extérieur Outside | Innen Intérieur Inside | | | | | X | Glasleisten Parcloses Glazing beads |
|--|--|--|--|--|--|--|-----|--|
| | 455.608  | 455.610  | 455.610  | 455.610  | 455.609  | 455.609  | | |
| Verglasung F Vitrage F Glazing F | 5 | | | | | 3 | 7.5 |  405.035 |
| | | 5 | 6 | 7 | 8 | 9 | 7.5 |  405.034 |
| | | 10 | 11 | 12 | 13 | 14 | 7.5 |  405.033 |
| | | 15 | 16 | 17 | 18 | 19 | 7.5 |  405.032 |
| | | 20 | 21 | 22 | 23 | 24 | 7.5 |  405.031 |
| | | 25 | 26 | 27 | 28 | 29 | 7.5 |  405.030 |

Einbausituationen Glasleisten
 ab Seite 77 beachten

Tenir compte des situations de montage
 des parcloses à partir de la page 77

Observe installation situations for
 glazing beads from page 77

Verglasungsvarianten

Variantes de vitrage

Alternative glazing

Jansen Art'15

Jansen Art'15

Jansen Art'15

Wichtiger Hinweis: Trockenverglasung

Grundlage der Verglasungstabelle sind die Nennmasse der Profile und Füllelemente. Bedingt durch verschiedene Toleranzen (Profile, Glasleisten, Anordnung Befestigungsknöpfe, Glasdichtungen und Glaselemente) empfehlen wir, die Wahl der inneren Glasdichtungen vorgängig an einem Element zu prüfen.

Gegebenenfalls kommt die nächst kleinere oder grössere Glasleiste/Dichtung zur Anwendung.

Die Masse entsprechen ungefähr einer rahmenbündigen Glasleisten-Montage.

Wir empfehlen, die Glasleisten nur auf der Raumseite anzuwenden.

Remarque importante: Vitrage à sec

Les cotes nominales des profilés et des éléments de remplissage sont la base du tableau de vitrage. A cause des différentes tolérances (profilés, parclose, disposition boutons de fixation, bandes de distance et éléments vitrés) nous recommandons d'effectuer un essai préalable avec le joint intérieur choisi sur un élément.

Le cas échéant, utiliser la parclose / le joint de la taille inférieure ou supérieure.

Les distances correspondent à peu près au montage des parclose à fleur du cadre.

Nous recommandons de n'utiliser les parclose que du côté intérieur.

Important notice: Dry glazing

The glazing table is based on the nominal dimensions of the profiles and infill panels. Owing to variations in the tolerances (profiled sections, glazing beads, layout of fastening studs, glazing seals and glazing) it is advisable to check your choice of inside glazing seals on an infill panel beforehand. If necessary the next smaller or larger size glazing bead/weatherstrip can be used.

Distances correspond approximately to glazing beads mounted flush to the frame.

We recommend fitting the glazing beads on the room-side only.

Wichtiger Hinweis: Nassverglasung

Grundlage der Verglasungstabelle sind die Nennmasse der Profile und Füllelemente. Bedingt durch verschiedene Toleranzen (Profile, Glasleisten, Anordnung Befestigungsknöpfe und Glaselemente) empfehlen wir, die Wahl der inneren Distanzbänder vorgängig an einem Element zu prüfen.

Gegebenenfalls kommt die nächst kleinere oder grössere Glasleiste/Distanzband zur Anwendung.

Die Masse entsprechen ungefähr einer rahmenbündigen Glasleisten-Montage.

Wir empfehlen, die Glasleisten nur auf der Raumseite anzuwenden.

Remarque importante: Vitrage à mastic

Les cotes nominales des profilés et des éléments de remplissage sont la base du tableau de vitrage. A cause des différentes tolérances (profilés, parclose, disposition boutons de fixation et éléments vitrés) nous recommandons d'effectuer un essai préalable avec la bande d'écartement choisie sur un élément. Le cas échéant, utiliser la parclose / la bande d'écartement de la taille inférieure ou supérieure.

Les distances correspondent à peu près au montage des parclose à fleur du cadre.

Nous recommandons de n'utiliser les parclose que du côté intérieur.

Important notice: Glazing with sealing

The glazing table is based on the nominal dimensions of the profiles and infill panels. Owing to variations in the tolerances (profiled sections, glazing beads, layout of fastening studs and glazing) it is advisable to check your choice of inside spacing tapes on an infill panel beforehand. If necessary the next smaller or larger size glazing bead/packing tape can be used.

Distances correspond approximately to glazing beads mounted flush to the frame.

We recommend fitting the glazing beads on the room-side only.

Betreffend Fugendimensionierung und Fugenausbildung verweisen wir auf die DIN-Normen 18545, resp. auf die Richtlinien der Glashersteller.

En ce qui concerne le dimensionnement et la formation des joints nous renvoyons au norme DIN 18545, respectivement aux directives du fabricant de verre.

Referring to joint dimensioning and joint form we refer you to DIN standard 18545, respectively to the guidelines of glass manufacturer.



455.006

Türdichtung
EPDM, schwarz

VE = 100 m

* Vor der Montage entfernen

455.006

Joint de porte
EPDM, noir

UV = 100 m

* A enlever avant le montage

455.006

Door weatherstrip
EPDM, black

PU = 100 m

* Remove before fitting



455.201

Schwelldichtung
EPDM, schwarz,
Lappenlänge 14 mm

VE = 25 m

455.201

Joint de seuil
EPDM, noir,
longueur lèvres 14 mm

UV = 25 m

455.201

Threshold weatherstrip
EPDM, black,
lip length 14 mm

PU = 25 m

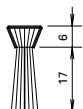

455.295 VE = 1 m
455.296 VE = 4,5 m

Bürste
Nylon, schwarz,
mit mittiger, dünner PE-Folie

455.295 UV = 1 m
455.296 UV = 4,5 m

Brosse
nylon, noir, avec film fin en PE
au centrée

455.295 PU = 1 m
455.296 PU = 4,5 m

Brush
nylon, black, with thin PE foil
in the centre



455.405

**Stulpdichtungsstück für
zweiflügelige Türen**
aus Polyamid schwarz,
durch Metallbauer zu kürzen,
links und rechts verwendbar

Einsatz:
Im Stulpbereich beim
Standflügel unten und oben

VE = 20 Stück

455.405

**Embout d'étanchéité pour
porte à deux vantaux**
en polyamide noir, à raccourcir
par le métallier, utilisable à à
gauche et à droite.

Utilisation:
Pour le fenêtres à deux vantaux
en haut et en bas

UV = 20 pièces

455.405

**Weatherstrip for double
leaf doors**
made of black polyamide,
shortened by the metal
fabricator, can be used left
and right.

Usage:
Above and below of double
vent windows

PU = 20 pieces



455.044

Anschlagdichtung
EPDM, schwarz

VE = 100 m

Einsatz:
In Kombination mit
Zusatzprofil 407.965

455.044

Joint de butée
EPDM, noir

UV = 100

Utilisation:
En combinaison avec profilé com-
plémentaire 407.965

455.044

Rebate gasket
EPDM, black

PU = 100 m

Usage:
In combination with door
profile profile 407.965

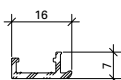

407.965

Zusatzprofil
Aluminium, roh

Gewicht 0,099 kg/m
U = 0,056 m²/m

Länge 6 m

Befestigung mit 555.486

407.965

Profilé complémentaire
aluminium brut

poids 0,099 kg/m
U = 0,056 m²/m

Longueur 6 m

Fixer avec 555.486

407.965

Additional profile
aluminium mill finish

weight 0,099 kg/m
U = 0,056 m²/m

Length 6 m

Fixing with 555.486

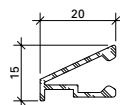

407.009

Wetterschenkel
Aluminium, roh

Gewicht 0,185 kg/m
U = 0,100 m²/m
P = 0,028 m²/m

Länge 6 m

Befestigungsknopf 450.006
Endstück 450.070

407.009

Renvoi d'eau
aluminium, brut

poids 0,185 kg/m
U = 0,100 m²/m
P = 0,028 m²/m

Longueur 6 m

Bouton de fixation 450.006
Embout 450.070

407.009

Weatherbar
aluminium, mill finish

weight 0,185 kg/m
U = 0,100 m²/m
P = 0,028 m²/m

Length 6 m

Fixing stud 450.006
End piece 450.070



450.070

Endstück
Kunststoff schwarz,
für Wetterschenkel 407.009

VE = je 5 Stück
(links und rechts)

450.070

Embout
matière plastique, noire,
pour renvoi d'eau 407.009

UV = 5 paires
(gauche et droite)

450.070

End piece
black, plastic,
for weatherbar 407.009

PU = 5 pieces each
(left and right)

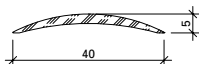

407.040

Schwelle

Aluminium, roh

Gewicht 0,200 kg/m

U = 0,084 m²/m

P = 0,043 m²/m

Länge 6 m

407.040

Seuil

aluminium brut

poids 0,200 kg/m

U = 0,084 m²/m

P = 0,043 m²/m

Longueur 6 m

407.040

Threshold

aluminium mill finish

weight 0,200 kg/m

U = 0,084 m²/m

P = 0,043 m²/m

Length 6 m

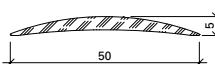

407.041

Schwelle

Aluminium, roh

Gewicht 0,325 kg/m

U = 0,104 m²/m

P = 0,053 m²/m

Länge 6 m

407.041

Seuil

aluminium brut

poids 0,325 kg/m

U = 0,104 m²/m

P = 0,053 m²/m

Longueur 6 m

407.041

Threshold

aluminium mill finish

weight 0,325 kg/m

U = 0,104 m²/m

P = 0,053 m²/m

Length 6 m

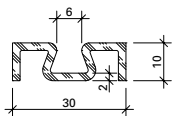

407.101

Zusatzprofil

Aluminium, roh

Gewicht 0,310 kg/m

U = 0,130 m²/m

P = 0,044 m²/m

Länge 6 m

407.101

Profilé complémentaire

aluminium brut

poids 0,310 kg/m

U = 0,130 m²/m

P = 0,044 m²/m

Longueur 6 m

407.101

Additional profile

aluminium mill finish

weight 0,310 kg/m

U = 0,130 m²/m

P = 0,044 m²/m

Length 6 m



450.030 9 x 4 mm
450.031 9 x 5 mm
450.032 9 x 6 mm
450.034 9 x 8 mm
450.035 14 x 4 mm
450.036 14 x 5 mm
450.037 14 x 6 mm

Distanzband
Zellpolyethylen,
geschlossen, weiss,
selbstklebend

VE = 50 m

450.030 9 x 4 mm
450.031 9 x 5 mm
450.032 9 x 6 mm
450.034 9 x 8 mm
450.035 14 x 4 mm
450.036 14 x 5 mm
450.037 14 x 6 mm

Bande d'écartement
polyéthylène cellulaire,
à cellules fermées, blanche,
auto-adhésive

UV = 50 m

450.030 9 x 4 mm
450.031 9 x 5 mm
450.032 9 x 6 mm
450.034 9 x 8 mm
450.035 14 x 4 mm
450.036 14 x 5 mm
450.037 14 x 6 mm

Packing tape
closed cell polyethylene,
white, self-adhesive

PU = 50 m



450.060 9 x 4 mm
450.061 9 x 5 mm
450.062 9 x 6 mm
450.064 9 x 8 mm

Distanzband
Zellpolyethylen,
geschlossen, schwarz,
selbstklebend

VE = 50 m

450.060 9 x 4 mm
450.061 9 x 5 mm
450.062 9 x 6 mm
450.064 9 x 8 mm

Bande d'écartement
polyéthylène cellulaire,
à cellules fermées, noire,
auto-adhésive

UV = 50 m

450.060 9 x 4 mm
450.061 9 x 5 mm
450.062 9 x 6 mm
450.064 9 x 8 mm

Packing tape
closed cell polyethylene,
black, self-adhesive

PU = 50 m



455.608

Glasdichtung

EPDM, schwarz, für Profil-
anschlagseite, selbstklebend,
Fugenbreite 5 mm

Einsatz siehe Seite 11

VE = 50 m

455.608

Joint de vitrage

EPDM, noir, pour côté
aile fixe, autocollant,
largeur du joint 5 mm

Utilisation voir page 11

UV = 50 m

455.608

Glazing weatherstrip

EPDM, black, for section
flange, self-adhesive,
joint width 5 mm

Application see page 11

PU = 50 m



455.609

Glasdichtung mit Abreisstege

EPDM, schwarz,
für Glasleistenseite,
Fugenbreite 4-5 mm

Einsatz siehe Seite 11

VE = 50 m

455.609

Joint de vitrage avec partie déchirable

EPDM, noir,
pour côté parclose,
largeur du joint 4-5 mm

Utilisation voir page 11

UV = 50 m

455.609

Glazing weatherstrip with detachable strip

EPDM, black,
for glazing bead side,
joint width 4-5 mm

Application see page 11

PU = 50 m

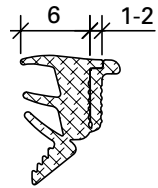

455.610

Glasdichtung mit Abreisstege

EPDM, schwarz,
für Glasleistenseite,
Fugenbreite 6-8 mm

Einsatz siehe Seite 11

VE = 50 m

455.610

Joint de vitrage avec partie déchirable

EPDM, noir,
pour côté parclose,
largeur du joint 6-8 mm

Utilisation voir page 11

UV = 50 m

455.610

Glazing weatherstrip with detachable strip

EPDM, black,
for glazing bead side,
joint width 6-8 mm

Application see page 11

PU = 50 m



450.159

Reiniger

zur Reinigung der beschichteten
Profile vor dem Anbringen der
selbstklebenden Anschlagdich-
tungen

VE = 1 Flasche à 500 ml

450.159

Nettoyant

pour le nettoyage des profilés
revêtus avant la pose des joints
des butées autocollants

UV = 1 bouteille de 500 ml

450.159

Cleaner

for cleaning the coated profiles
before attaching self-adhesive re-
bate gaskets

PU = 1 x 500 ml bottle



450.152

Primer

für eine bessere Haftung beim
Anbringen der selbstklebenden
Anschlagdichtungen

VE = 1 Flasche à 1 Liter

450.152

Couche de fond

pour une meilleure adhérence lors
de la pose des joints des butées
autocollants

UV = 1 bouteille de 1 litre

450.152

Primer

for improved adhesion when
attaching bonded self-adhesive
rebate gaskets

PU = 1 x 1 litre bottle



450.091

Reiniger

zur Reinigung aller Teile vor dem Anbringen der Dichtmasse 450.092

VE = 1 Liter

450.091

Nettoyant

pour nettoyer toutes les pièces avant d'appliquer la pâte à étancher 450.092

UV = 1 litre

450.091

Cleaner

for cleaning all components before applying the sealing compound 450.092

PU = 1 litre



450.092

Kleb- und Dichtmasse

schwarz, für das Abdichten der Dichtungs-Stösse und -Durchbrüche

VE = 1 Stück (à 290 ml)

Wichtig:
Ohne Vorbehandlung mit Reiniger 450.091 ist die Klebhaftung nicht gewährleistet.

450.092

Pâte à coller et à étancher

noire, pour étancher les raccords et les points de raccords des joints intérieurs

UV = 1 pièce (à 290 ml)

Important:
Sans traitement préliminaire avec un nettoyant 450.091, l'adhésion n'est pas garantie.

450.092

Sealing and bonding compound

black, for sealing the joints and holes in the weatherstrip

PU = 1 piece (à 290 ml)

Important:
Adhesion cannot be guaranteed unless cleaner 450.091 has been used as a pre-treatment.



450.106

Dichtmasse

transparent, Silikon dünnflüssig, für Abdichtungen von kleinen Fugen, inkl. Ausspritzdüsen

VE = 2 Stück (à 310 ml)

450.106

Pâte d'étanchéité

transparente, silicone fluide, pour étanchéification de petits joints, avec gicleurs d'éjection

UV = 2 pièces (à 310 ml)

450.106

Sealing compound

transparent, thin silicone, for sealing small joints, includes spray nozzles

PU = 2 pieces (à 310 ml)



450.093

Fliessfett

für die Schmierung der Jansen-Bänder

VE = 1 Flasche à 500 g
2 Dosierflaschen

450.093

Graisse fluide

pour le graissage des paumelles Jansen

UV = 1 flacon de 500 g
2 flacons doseurs

450.093

Lubrication

for lubricating Jansen hinges

PU = 1 bottle each 500 g
2 dosing bottles



450.089

Spezialkleber

farblos, schnell härtend, klebt Kunststoffe und Gummi

VE = 1 Dose à 20 g

450.089

Colle spéciale

incolor, à durcissement rapide, pour matières plastiques et caoutchouc

UV = 1 boîte à 20 g

450.089

Special adhesive

colourless, fast-curing, bonds plastics and rubber

PU = 1 x 20 g can



555.064

3D-Anschweisband links
Stahl, Länge 108 mm,
ø 13 mm

VE = 2 Stück

555.064

Paumelle à souder, gauche
acier, longueur 108 mm,
ø 13 mm

UV = 2 pièces

555.064

Weld-on hinge, left
steel, length 108 mm,
ø 13 mm

PU = 2 pieces



555.065

3D-Anschweisband rechts
Stahl, Länge 108 mm,
ø 13 mm

VE = 2 Stück

555.065

Paumelle à souder, droite
acier, longueur 108 mm,
ø 13 mm

UV = 2 pièces

555.065

Weld-on hinge, right
steel, length 108 mm,
ø 13 mm

PU = 2 pieces



499.544

Montagedorn
Edelstahl, roh

VE = 2 Stück

499.544

Axe de montage
acier Inox, brut

UV = 2 pièces

499.544

Assembly jig
stainless steel, mill finish

PU = 2 pieces



499.180

Anschweislehre
für Anschweisbänder 555.064
und 555.065

VE = 2 Stück

499.180

Gabarit de soudage
pour paumelles à souder
555.064 et 555.065

UV = 2 pièces

499.180

Welding jig
for weld-on hinges 555.064 and
555.065

PU = 2 pieces



550.229 Stahl gezogen

**Höhenverstellbares
Anschweisband**
Länge 180 mm, ø 20 mm,
Buchse und Druckscheibe aus
Spezial-Bronze, Dorn und Ver-
schluss-Schraube aus Edelstahl

Verstellbarkeit:
Höhe ± 4 mm

VE = 10 Stück

550.229 Acier étiré

**Paumelle à souder,
à hauteur réglable**
longueur 180 mm, ø 20 mm,
douille et rondelle en bronze,
tige et vis de fermeture en
acier Inox

Réglable:
Hauteur ± 4 mm

UV = 10 pièces

550.229 Drawn steel

**Height-adjustable weld-on
hinge**
length 180 mm, ø 20 mm,
sleeve and washer made of
special bronze, spindle and
screw plug in stainless steel

Adjustable:
Height ± 4 mm

PU = 10 pieces

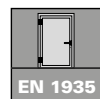

557.182 links
557.183 rechts

3D Anschraubband
Edelstahl matt 1.4301,
inkl. Befestigungsschrauben

VE = 2 Stück

Einbau mit 499.522

Hinweis:

Ab Flügelhöhe 1200 mm ist ein zusätzliches Band erforderlich!

557.182 à gauche
557.183 à droite

Paumelle à visser 3D
acier Inox mat 1.4301,
y compris vis de fixation

UV = 2 pièces

Montage avec 499.522

Remarque:

Une paumelle supplémentaire est nécessaire à partir d'une hauteur de vantail de 1200 mm!

557.182 LH
557.183 RH

3D Screw-on hinge
stainless steel matt 1.4301,
includes fixing screws

PU = 2 pieces

Installation with 499.522

Note:

An additional hinge is required for a vent height of 1200 mm and above!



555.484

Anschraubband
Edelstahl 1.4301, ø 10 mm,
Länge 89 mm, mit Messing-
Zwischenring

VE = 10 Stück

Zusätzlich bestellen:
557.162 Schrauben
555.476 Unterlagsplättchen

555.484

Paumelle à visser
acier Inox 1.4301, ø 10 mm,
longueur 89 mm, avec bague
intermédiaire en laiton

UV = 10 pièces

Commander séparément:
557.162 Vis
555.476 Cale de compensation

555.484

Screw-on hinge
stainless steel 1.4301, ø 10 mm,
length 89 mm, with brass
intermediate ring

PU = 10 pieces

Order separately:
557.162 Screws
555.476 Base plate



550.190 ø 22 mm
550.191 ø 17 mm

Fallenriegel-Schloss
mit Wechsel, Riegelausschluss
1-tourig 20 mm, Kasten verzinkt,
Falle und Riegel vernickelt,
Stulp Edelstahl, Nuss 9 mm

VE = 1 Fallenriegel-Schloss

Zusätzlich bestellen:
555.490 Schrauben
555.720 Schliessblech

Hinweis:

Schlösser mit Dornmass 30 mm über Sonderbestellung möglich.

550.190 ø 22 mm
550.191 ø 17 mm

Serrure à mortaiser
avec levier, course du pêne à
1 tour 20 mm, boîtier zingué,
bec de cane et pêne nickelés,
têtière en acier Inox,
fouillot 9 mm

UV = 1 serrure à mortaiser

Commander séparément:
555.490 Vis
555.720 Gâche de fermeture

Remarque:

Serrures avec axe canon/ têtière 30 mm possible sur commande spéciale.

550.190 ø 22 mm
550.191 ø 17 mm

Latch and bolt lock
with latch retention, travel
of bolt 1 turn 20 mm, case
galvanised, latch and bolt
nickel-plated, face plate
stainless steel, spindle 9 mm

PU = 1 latch and bolt lock

Order separately:
555.490 Screws
555.720 Strike plate

Note:

Locks with backset 30 mm possible by special order.



550.192 ø 22 mm

550.193 ø 17 mm

Rollfallen-Schloss

Riegelausschluss 1-tourig
20 mm, Kasten verzinkt,
verstellbare Rollfalle, Riegel
vernickelt, Stulp Edelstahl

VE = 1 Rollfallen-Schloss

Zusätzlich bestellen:

555.490 Schrauben
555.721 Schliessblech

550.192 ø 22 mm

550.193 ø 17 mm

Serrure à mortaiser à rouleau

course du pêne à 1 tour 20 mm,
boîtier zingué, rouleau réglable,
pêne nickelés, têtère en
acier Inox

UV = 1 serrure à mortaiser à
rouleau

Commander séparément:

555.490 Vis
555.721 Gâche de fermeture

550.192 ø 22 mm

550.193 ø 17 mm

Roller latch lock

travel of bolt 1 turn 20 mm,
case galvanised, adjustable
roller latch, bolt nickel-plated,
face plate stainless steel

PU = 1 roller latch lock

Order separately:

555.490 Screws
555.721 Strike plate



557.192

Kantenriegel

Aluminium, schwarz,
Verriegelungsstück aus Stahl,
Länge 140 mm, für Verriegelung
des Standflügels, inkl. 1 Büchse
aus Edelstahl und
3 Befestigungsschrauben

VE = 1 Stück

557.192

Verrou à bascule

aluminium, noir, pièce de
verrouillage en acier, longueur
140 mm, pour le verrouillage du
vantail semi-fixe, avec 1 douille en
acier Inox et 3 vis de fixation

UV = 1 pièce

557.192

Flush bolt

aluminium, black, keep made
from steel, length 140 mm,
for locking the secondary vent,
Including 1 stainless steel socket
and 3 fixing screws

PU = 1 piece



557.139

Kantenriegel

Aluminium, schwarz,
Verriegelungsstück aus Stahl,
Länge 225 mm, für Verriegelung
des Standflügels, inkl. 1 Büchse
aus Edelstahl und
3 Befestigungsschrauben

VE = 1 Stück

Hinweis:

Lage der Verriegelungspunkte
anpassen.

557.139

Verrou à bascule

aluminium, noir, pièce de
verrouillage en acier, longueur
225 mm, pour le verrouillage du
vantail semi-fixe, avec 1 douille en
acier Inox et 3 vis de fixation

UV = 1 pièce

Remarque:

Adapter la position des points
de verrouillage.

557.139

Flush bolt

aluminium, black, keep made
from steel, length 225 mm,
for locking the secondary vent,
Including 1 stainless steel socket
and 3 fixing screws

PU = 1 piece

Note:

Adjust position of the
locking points.



559.210 ø 17 mm

Fallenriegel-Schloss
für Profile mit Körperbreite
25 mm, mit Wechsel, Dornmass
18 mm, **Nuss 8x8 mm**,
Stulp Edelstahl, Schlosskasten
verzinkt, links und rechts
umstellbar, Riegelausschluss
1-tourig 11 mm

VE = 1 Fallenriegel-Schloss

Zusätzlich bestellen:
555.490 Schrauben
559.217 Schliessblech
559.213 Dorn

559.210 ø 17 mm

Serrure à mortaiser
pour profilés avec largeur
25 mm, avec levier, axe canon/
tête en acier Inox, boîtier
zingué, utilisable à droite et
à gauche, course du pêne à
1 tour 11 mm

UV = 1 serrure à mortaiser

Commander séparément:
555.490 Vis
559.217 Gâche de fermeture
559.213 Tige

559.210 ø 17 mm

Latch and bolt lock
for profiles with face width
25 mm, with latch retention,
backset 18 mm, **8x8 mm boss**,
stainless steel face plate,
galvanised casing, can be used
left and right, travel of bolt
1 turn 11 mm

PU = 1 latch and bolt lock

Order separately:
555.490 Screws
559.217 Strike plate
559.213 Spindle



559.213

Vierkant-Dorn 8 mm
Stahl gehärtet, verzinkt,
Länge 100 mm

VE = 5 Stück

559.213

Tige carrée 8 mm
acier trempé, zingué,
longueur 100 mm

UV = 5 pièces

559.213

Square spindle 8 mm
steel reinforced, galvanised,
length 100 mm

PU = 5 pieces



555.720

Schliessblech

Edelstahl, für Fallenriegel-Schlösser 550.191, links und rechts einsetzbar

VE = 1 Schliesblech

Zusätzlich bestellen:
555.490 Schrauben

555.720

Gâche de fermeture

acier Inox, pour serrures à mortaiser 550.191, utilisable à gauche et à droite

UV = 1 gâche de fermeture

Commander séparément:
555.490 Vis

555.720

Strike plate

stainless steel, for latch and bolt locks 550.191, can be used LH and RH

PU = 1 strike plate

Order separately:
555.490 Screws



555.721

Schliessblech

Edelstahl, für Rollfallen-Schlösser 550.193, links und rechts einsetzbar

VE = 1 Schliesblech

Zusätzlich bestellen:
555.490 Schrauben

555.721

Gâche de fermeture

acier Inox, pour serrures à mortaiser à rouleau 550.193, utilisable à gauche et à droite

UV = 1 gâche de fermeture

Commander séparément:
555.490 Vis

555.721

Strike plate

stainless steel, for roller latch locks 550.193, can be used LH and RH

PU = 1 strike plate

Order separately:
555.490 Screws



559.217

Schliessblech

Edelstahl, zu Schloss 559.210, links und rechts einsetzbar

VE = 1 Schliesblech

Zusätzlich bestellen:
555.490 Schrauben

559.217

Gâche de fermeture

acier Inox, pour serrure 559.210, utilisable à gauche et à droite

UV = 1 gâche de fermeture

Commander séparément:
555.490 Vis

559.217

Strike plate

stainless steel, for lock 559.210, can be used LH and RH

PU = 1 strike plate

Order separately:
555.490 Screws



555.466

Kantenbascule

Stulp Edelstahl, Hub 14 mm,
Anschlussgewinde M5,
Verwendung zusammen mit
Treibriegelstangen M5
(555.418/419)

VE = 1 Kantenbascule

Einbau mit
499.149 ø 22 mm
499.150 ø 17 mm

Bei Bedarf zusätzlich bestellen:

555.490 Schrauben
559.241/ Standflügelverriegelung
559.242
555.418/ Treibriegelstange
555.419

555.466

Verrou à entailler à bascule

têtière en acier Inox, course
14 mm, raccord taraudé M5,
à utiliser avec tiges de
verrouillage M5 (555.418/419)

UV = 1 verrou à entailler à
bascule

Montage avec
499.149 ø 22 mm
499.150 ø 17 mm

Commander en plus si besoin:

555.490 Vis
559.241/ Verrouillage pour
559.242 vantail semi-fixe
555.418/ Tige de verrouillage
555.419

555.466

Espagnolette

face plate stainless steel, travel
14 mm, connecting thread M5,
use in conjunction with shoot
bolts M5 (555.418/419)

PU = 1 espagnolette

Installation with
499.149 ø 22 mm
499.150 ø 17 mm

Order separately if required:

555.490 Screws
559.241 Additional set for
559.242 secondary leaf
555.418/ Shoot bolt
555.419



555.418 1,5 m

Treibriegelstange oben

Stahl verzinkt, ø 10 x 1,5 mm,
mit Gewindeteil M5, mit
Kunststoff-Endstopfen, für
Kantenbascule 555.466

VE = 1 Stück

555.418 1,5 m

Tige de verrouillage supérieure

acier zingué, ø 10 x 1,5 mm,
avec filetage M5, avec embout
en plastique, pour verrou à
entailler à bascule 555.466

UV = 1 pièce

555.418 1,5 m

Shoot bolt (top)

galvanised steel, ø 10 x 1,5 mm,
with M5 thread, with plastic
end stopper, for espagnolette
555.466

PU = 1 piece



555.419 1,42 m

Treibriegelstange unten

Stahl verzinkt, ø 10 mm,
mit Gewindeteil M5,
ohne Endstopfen,
für Kantenbascule 555.466

VE = 1 Stück

555.419 1,42 m

Tige de verrouillage inférieure

acier zingué, ø 10 mm,
avec filetage M5, sans embout,
pour verrou à entailler à
bascule 555.466

UV = 1 pièce

555.419 1,42 m

Shoot bolt (bottom)

galvanised steel, ø 10 mm,
with M5 thread, without end
stopper, for espagnolette 555.466

PU = 1 piece

Beschläge**Ferrures****Fittings**

Jansen Art'15

Jansen Art'15

Jansen Art'15

**555.913****Edelstahl-Drücker**

matt, mit Ovalrosette
65x30x3 mm, festdrehbar
gelagert, mit Hochhaltefeder,
Lochabstand 50 mm

Breite: 118 mm
Tiefe: 49 mm

VE = 2 Drücker inkl. Drückerstift
8/9/8 mm und Befestigungs-
schrauben

**555.913****Poignée en acier Inox**

mat, avec rosace ovale
65x30x3 mm, rivée tournante,
avec ressort de rappel, distance
des trous 50 mm

Largeur: 118 mm
Profondeur: 49 mm

UV = 2 poignées et tige carré
8/9/8 mm et vis de
fixation incl.

555.913**Stainless steel handle**

matt, with oval rosette
65x30x3 mm, fixed swivel
mounted, with return spring,
distance of hole 50 mm

Width: 118 mm
Depth: 49 mm

PU = 2 handles incl. handle
spindle 8/9/8 mm and
fixing screws

**555.914****Edelstahl-Drücker**

poliert, mit Ovalrosette
65x30x3 mm festdrehbar
gelagert, mit Hochhaltefeder,
Lochabstand 50 mm

Breite: 118 mm
Tiefe: 49 mm

VE = 2 Drücker inkl. Drückerstift
8/9/8 mm und Befestigungs-
schrauben

**555.914****Poignée en acier Inox**

poli, avec rosace ovale à clips
65x30x3 mm rivée tournante, avec
ressort de rappel, distance des
trous 50 mm

Largeur: 118 mm
Profondeur: 49 mm

UV = 2 poignées et tige carré
8/9/8 mm et vis de
fixation incl.

555.914**Stainless steel handle**

polished, with oval rosette
65x30x3 mm, fixed swivel
mounted, with return spring,
distance of hole 50 mm

Width: 118 mm
Depth: 49 mm

PU = 2 handles incl. handle
spindle 8/9/8 mm and
fixing screws

**555.915****Edelstahl-Drücker**

schwarz beschichtet, mit
Ovalrosette 65x30x3 mm
festdrehbar gelagert, mit Hoch-
haltefeder, Lochabstand 50 mm

Breite: 118 mm
Tiefe: 49 mm

VE = 2 Drücker inkl. Drückerstift
8/9/8 mm und Befestigungs-
schrauben

**555.915****Poignée en acier Inox**

revêtement noir, avec rosace
ovale à clips 65x30x3 mm rivée
tournante, avec ressort de rappel,
distance des trous 50 mm

Largeur: 118 mm
Profondeur: 49 mm

UV = 2 poignées et tige carré
8/9/8 mm et vis de
fixation incl.

555.915**Stainless steel handle**

colour-coated black, with oval
rosette 65x30x3 mm, fixed swivel
mounted, with return spring,
distance of hole 50 mm

Width: 118 mm
Depth: 49 mm

PU = 2 handles incl. handle
spindle 8/9/8 mm and
fixing screws



555.916

Oval-Zylinder-Rosette
für Profilzylinder ø 17 mm,
Edelstahl matt, 65/30/3 mm,
Lochabstand 50 mm

VE = 2 Rosetten
inkl. Befestigungsschrauben



555.916

Rosace cylindre ovale
pour cylindre profilé ø 17 mm,
acier Inox mat, 65/30/3 mm,
distance des trous 50 mm

UV = 2 rosaces
vis de fixation incl.

555.916

Oval cylinder rosette
for profile cylinders ø 17 mm,
matt stainless steel, 65/30/3 mm,
distance of hole 50 mm

PU = 2 rosettes
incl. fixing screws



555.917

Oval-Zylinder-Rosette
für Profilzylinder ø 17 mm,
Edelstahl poliert, 65/30/3 mm,
Lochabstand 50 mm

VE = 2 Rosetten
inkl. Befestigungsschrauben



555.917

Rosace cylindre ovale
pour cylindre profilé ø 17 mm,
acier Inox poli, 65/30/3 mm,
distance des trous 50 mm

UV = 2 rosaces
vis de fixation incl.

555.917

Oval cylinder rosette
for profile cylinders ø 17 mm,
polished stainless steel,
65/30/3 mm, distance of hole
50 mm

PU = 2 rosettes
incl. fixing screws



555.918

Oval-Zylinder-Rosette
für Profilzylinder ø 17 mm,
Edelstahl schwarz beschichtet,
65/30/3 mm, Lochabstand 50 mm

VE = 2 Rosetten
inkl. Befestigungsschrauben



555.918

Rosace cylindre ovale
pour cylindre profilé ø 17 mm,
acier Inox revêtement noir,
65/30/3 mm, distance des trous
50 mm

UV = 2 rosaces
vis de fixation incl.

555.918

Oval cylinder rosette
for profile cylinders ø 17 mm,
colour-coated black, stainless
steel, 65/30/3 mm, distance of
hole 50 mm

PU = 2 rosettes
incl. fixing screws

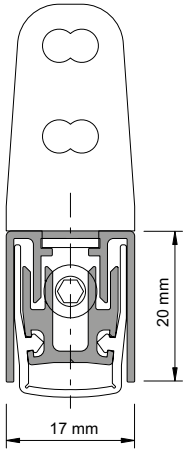

Automatische Senkdichtung

Aluminium, Dichtung aus Silikon, seitliche Befestigung mit Winkeln aus Edelstahl. links und rechts einsetzbar. Die Dichtungen lösen bandseitig aus und der Hub ist einstellbar bis 16 mm. Parallelabsenkung mit automatischem Ausgleich bei schiefem Boden. Einseitig kürzbar bis zur nächst kleineren Nennlänge.

VE = 1 Stück
4 Schrauben M4x7
2 Befestigungswinkel

Joint seuil automatique

aluminium, joint en silicone, fixation latérale par équerres en acier Inox, utilisable à gauche et à droite. Les joints se déclenchent côté paumelle et la course est réglable jusqu'à 16 mm. Abaissement parallèle avec compensation automatique sur sol en pente. Peut être raccourci d'un côté jusqu'à la longueur nominale inférieure la plus proche.

UV = 1 pièce
4 vis M4x7
2 équerres de fixation

Automatic drop seal

aluminium, weatherstrip made of silicone, lateral fastening with stainless steel brackets, can be used LH and RH. The weatherstrips are removed on the hinge side and the travel can be set at up to 16 mm. Parallel settlements with automatic compensation on sloping ground. Can be shortened on one side as far as the next smallest nominal length.

PU = 1 joint
4 screws M4x7
2 angled brackets

| Art.-Nr. | max. FFB mm | min. FFB mm |
|----------------|----------------|----------------|
| 555.366 | 400 | 275 |
| 555.367 | 550 | 400 |
| 555.368 | 700 | 550 |
| 555.369 | 850 | 700 |
| 555.370 | 900 | 850 |

| No d'art | max. FFB mm | min. FFB mm |
|----------------|----------------|----------------|
| 555.366 | 400 | 275 |
| 555.367 | 550 | 400 |
| 555.368 | 700 | 550 |
| 555.369 | 850 | 700 |
| 555.370 | 900 | 850 |

| Part no. | max. FFB mm | min. FFB mm |
|----------------|----------------|----------------|
| 555.366 | 400 | 275 |
| 555.367 | 550 | 400 |
| 555.368 | 700 | 550 |
| 555.369 | 850 | 700 |
| 555.370 | 900 | 850 |

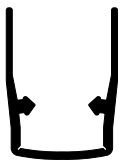

456.116

Dichtungsprofil

Silikon, Ersatzdichtung für automatische Senkdichtung 555.366-555.370

VE = 1,5 m

456.116

Profilé d'étanchéité

silicone, joint de remplacement pour joint seuil automatique 555.366-555.370

UV = 1,5 m

456.116

Gasket profile

silicone, spare gasket for automatic drop seal 555.366-555.370

PU = 1,5 m



555.490

Senkschraube M5x12

Stahl verzinkt, Edelstahl-Look,
SR1-Angriff, selbstgewindend,
100° Senkkopf, für die Befestigung
der Schlösser mit Edelstahl-
Stulp und Zubehör aus Edelstahl

Bohrdurchmesser ø 4,5 mm

VE = 500 Stück

555.490

Vis à tête fraisée M5x12

acier zingué, surface acier Inox,
empreinte SR1, autotaraudeuse,
tête noyée 100°, pour la fixation
des serrures avec têtière en acier
Inox et accessoires en acier Inox

Diamètre de perçage ø 4,5 mm

UV = 500 pièces

555.490

Countersunk screw M5x12

galvanised steel, stainless steel
surface, SR1 head, self-tapping,
100° countersunk, for fixing locks
with stainless steel face plate
and lock accessories

Hole diameter ø 4.5 mm

PU = 500 pieces



557.162

Schraube M4x7

Stahl verzinkt, Edelstahl-Look,
Torx-Angriff

Bohrdurchmesser 3,5 mm

VE = 100 Stück

557.162

Vis M4x7

acier zingué, surface acier Inox,
empreinte Torx

Diamètre de perçage 3,5 mm

UV = 100 pièces

557.162

Screw M4x7

galvanised steel, stainless steel
surface, Torx head

Hole diameter 3,5 mm

PU = 100 pieces

Definition Symbole

Définition des symboles

Definition of symbols

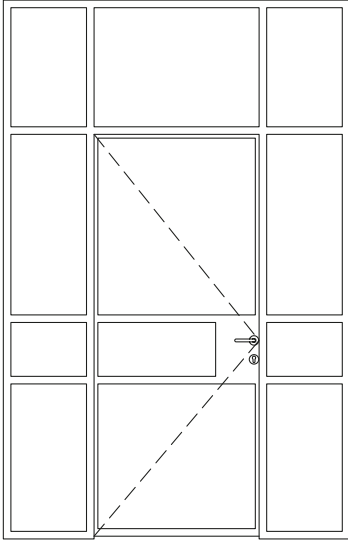

Türe einflügelig
nach innen öffnend

Porte à un vantail
ouvrant vers l'intérieur

Single-leaf door
inward opening

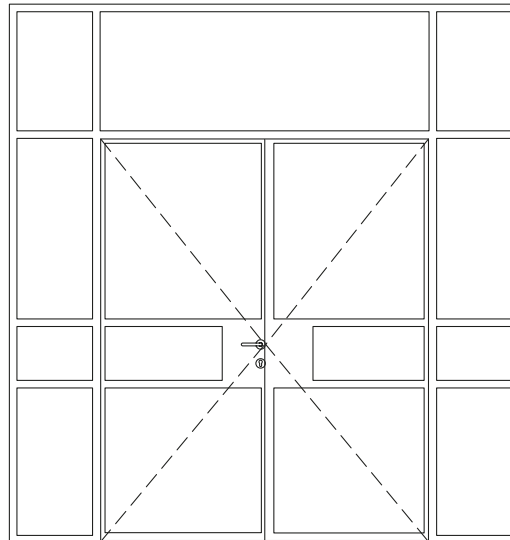

Türe zweiflügelig
nach innen öffnend

Porte à deux vantaux
ouvrant vers l'intérieur

Double-leaf door
inward opening

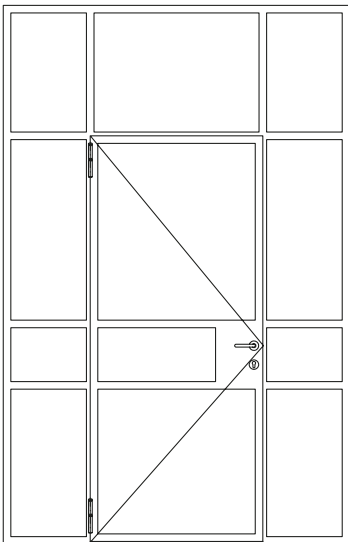

Türe einflügelig
nach aussen öffnend

Porte à un vantail
ouvrant vers l'extérieur

Single-leaf door
outward opening

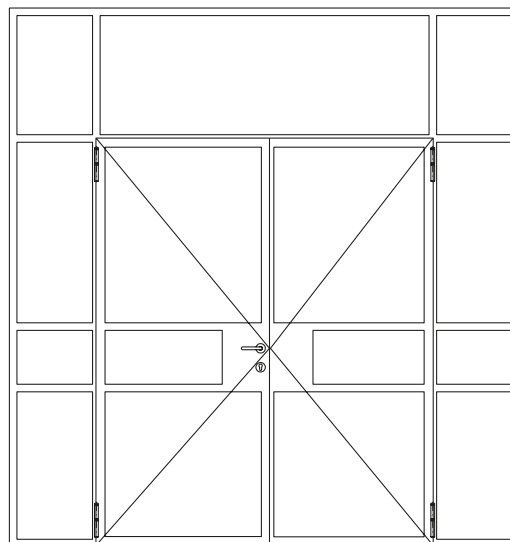

Türe zweiflügelig
nach aussen öffnend

Porte à deux vantaux
ouvrant vers l'extérieur

Double-leaf door
outward opening

Ausführungsvarianten

Modèles

Design range

Profilansicht aufschlagend
Face du profilé à recouvrement
Face-fitted profile view

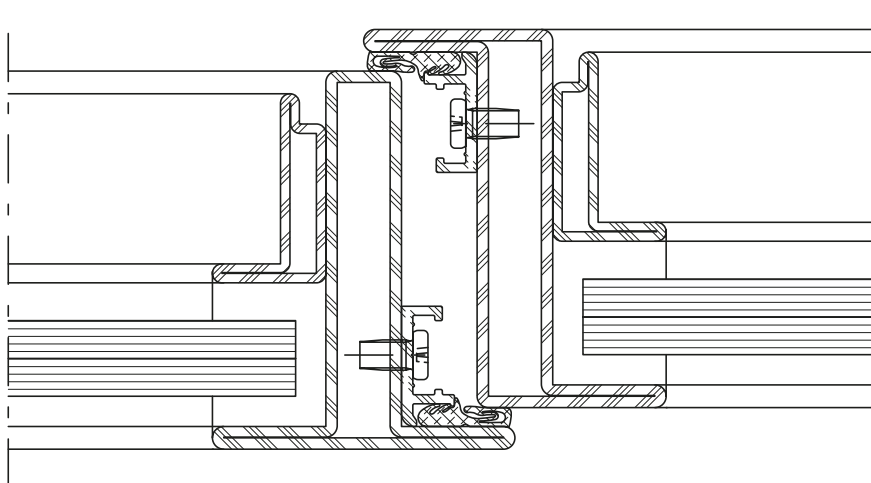

Profilansicht überschlagend
Face du profilé décalé à recouvrement
Rebated profile view

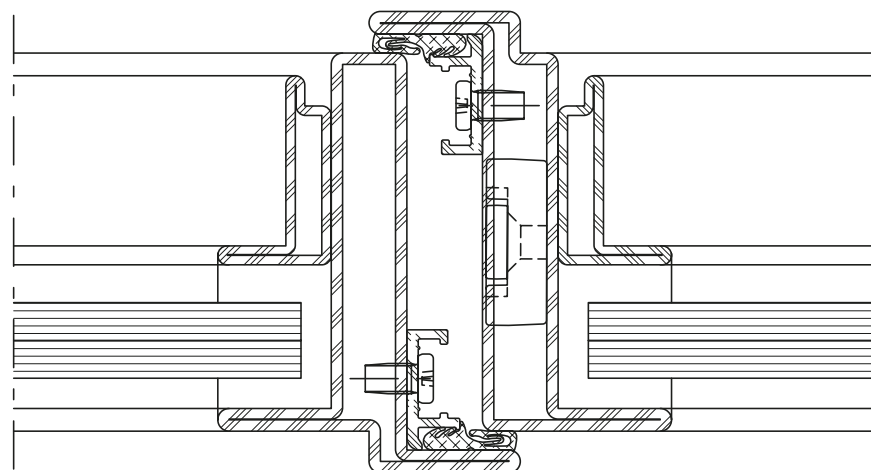

Profilansicht flächenbündig
Face du profilé à fleur
Flush-fitted profile view

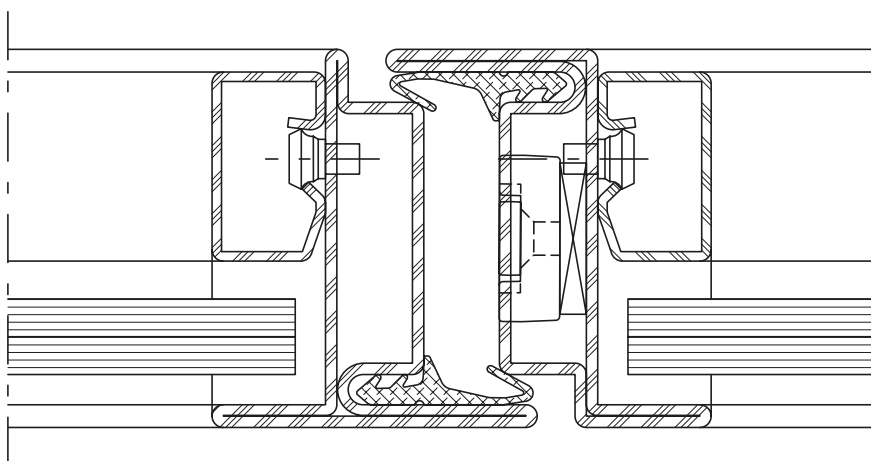

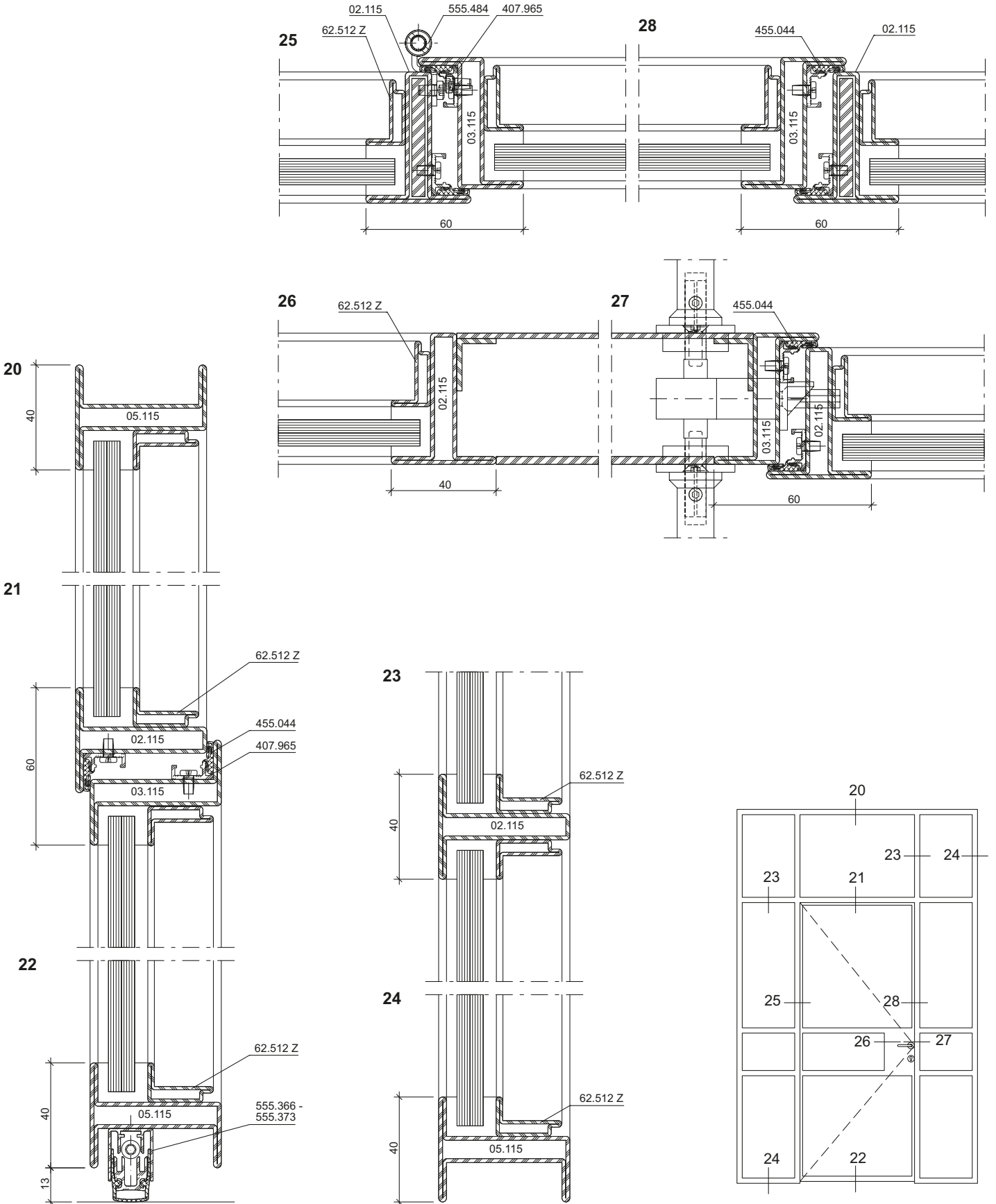

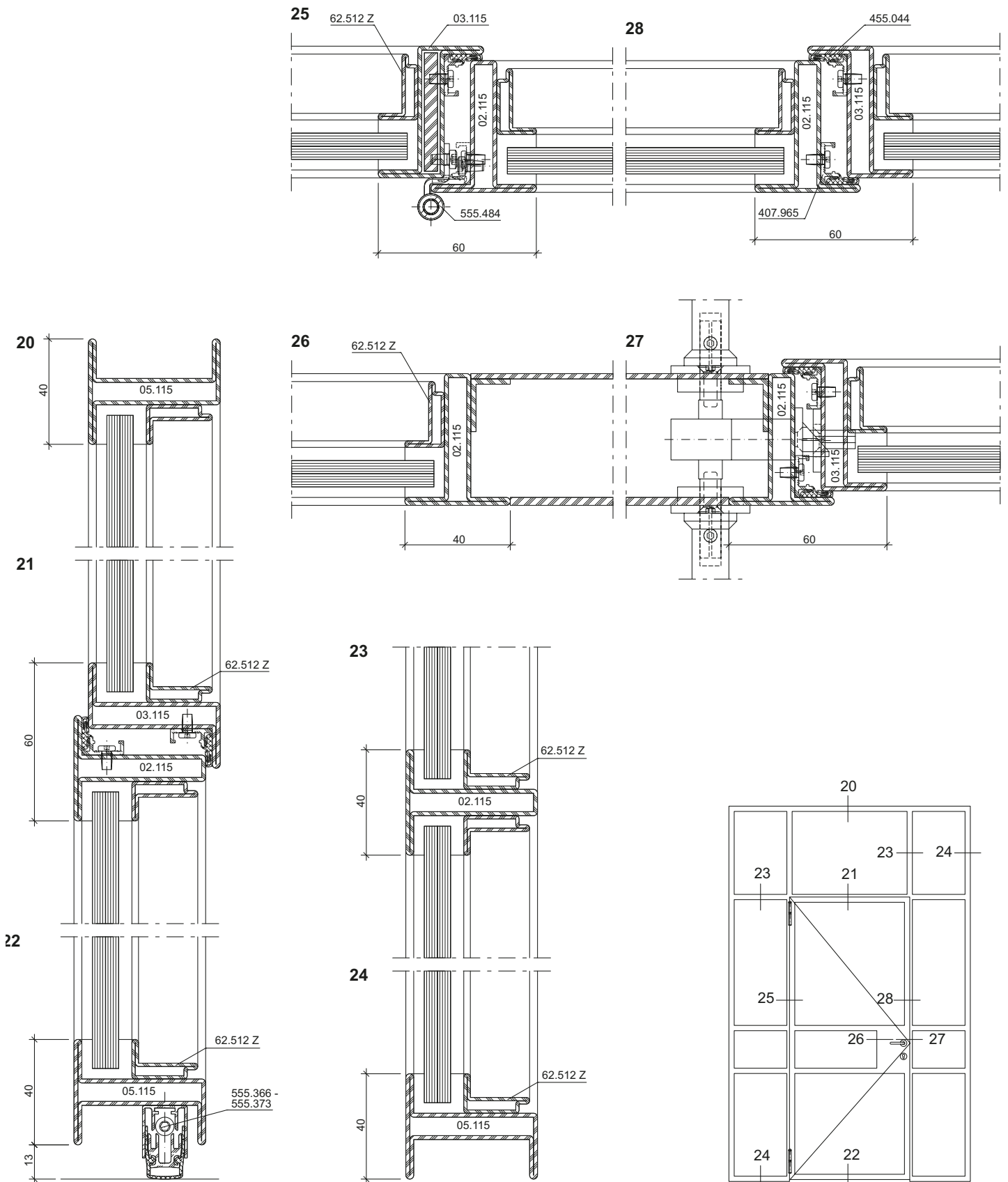

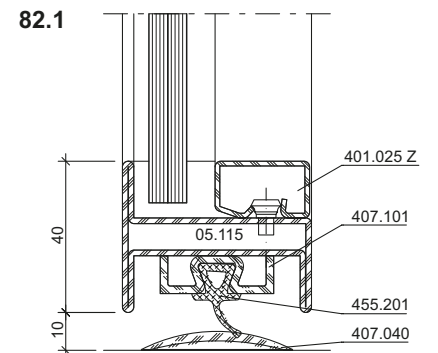
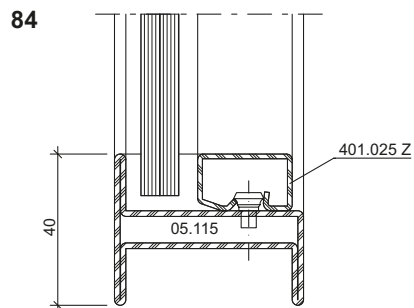
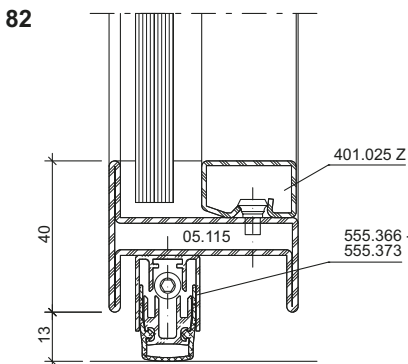
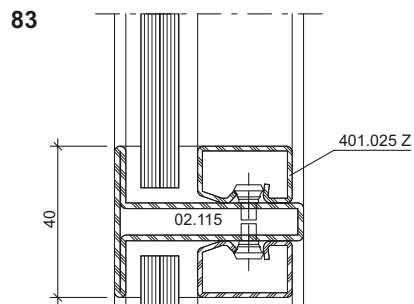
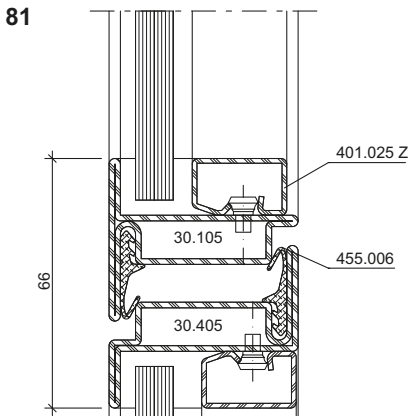
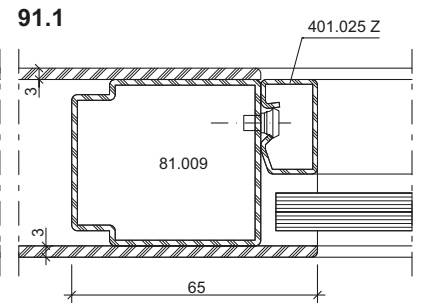
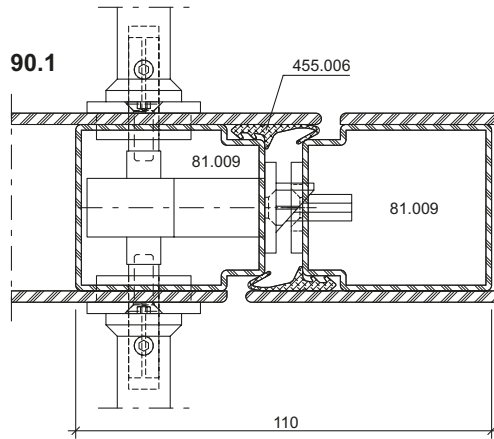
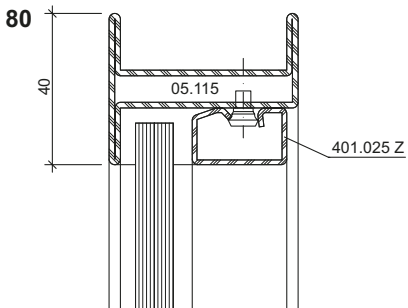
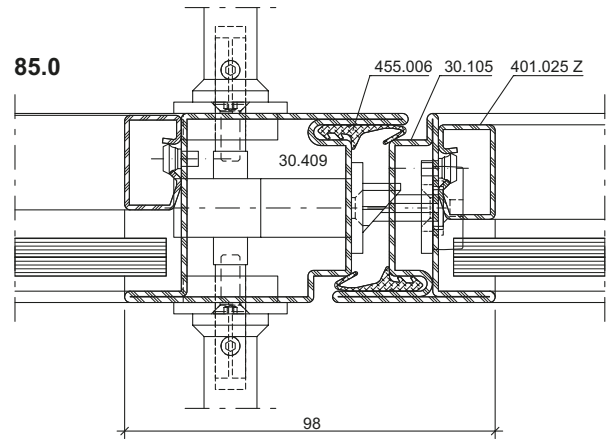
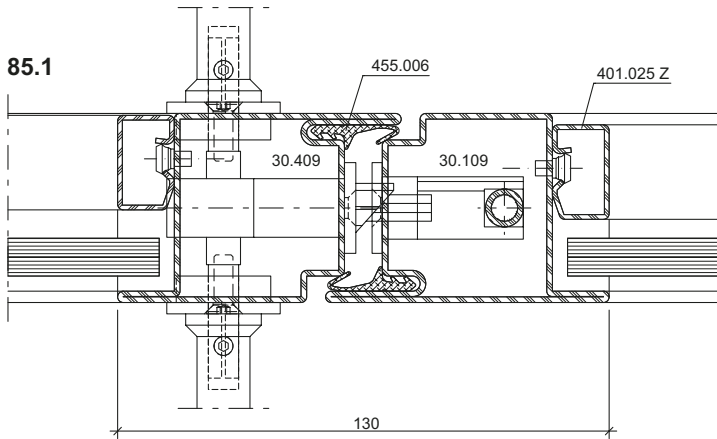

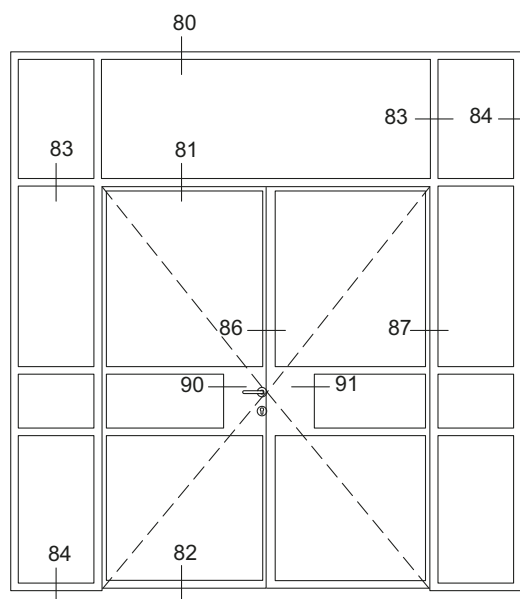
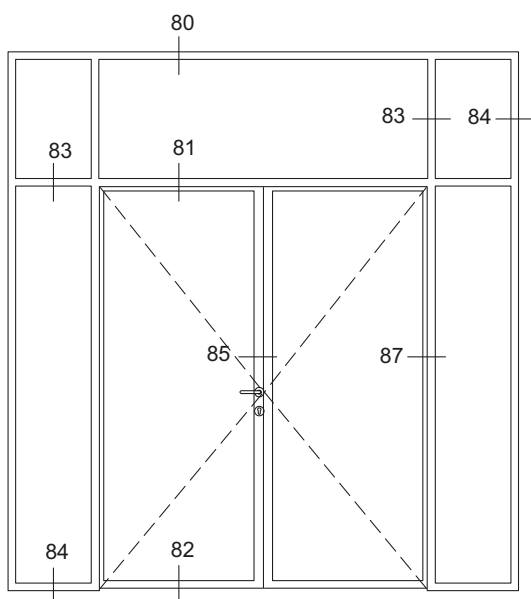
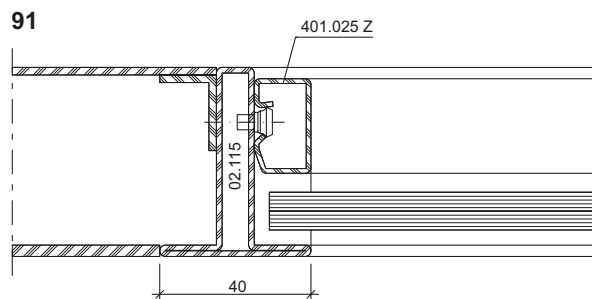
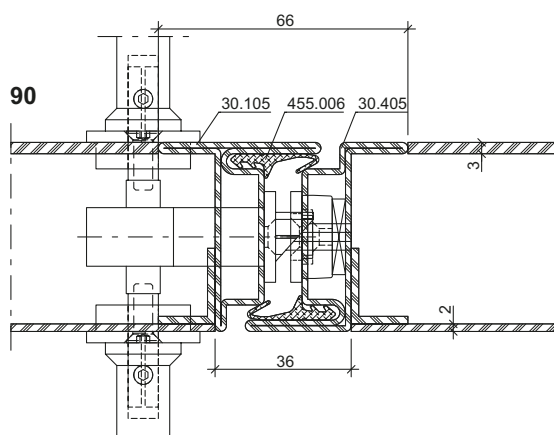
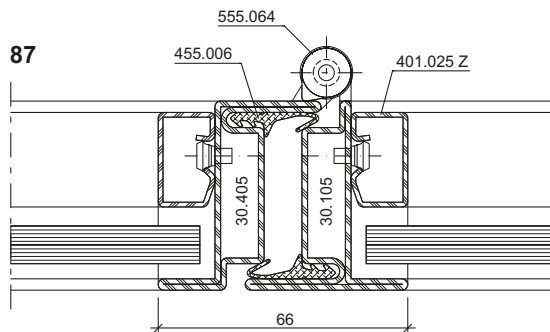
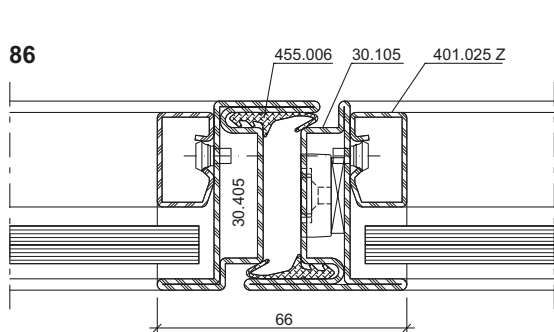

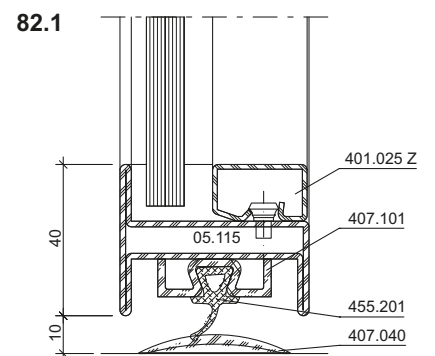
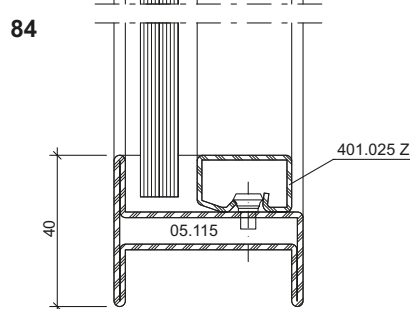
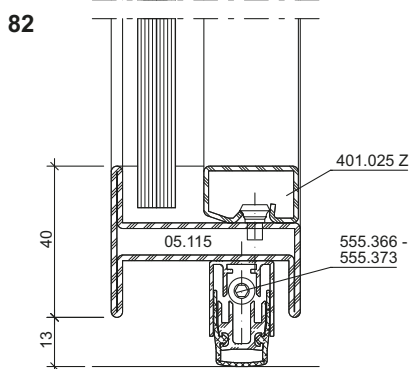
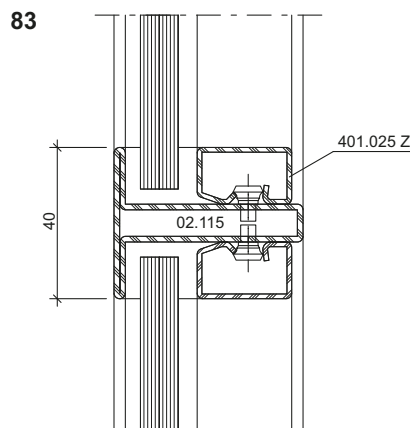
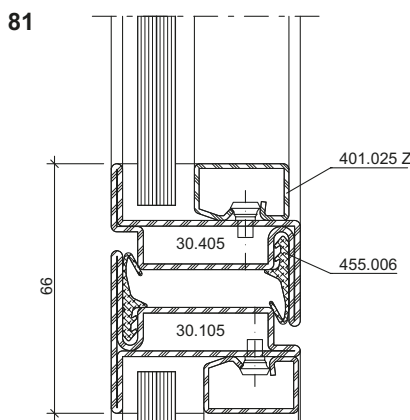
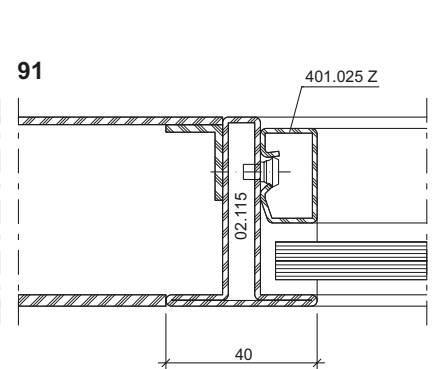
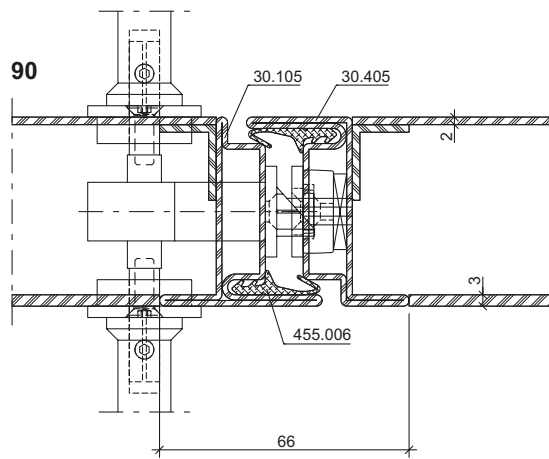
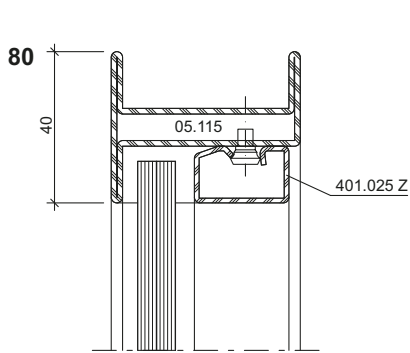
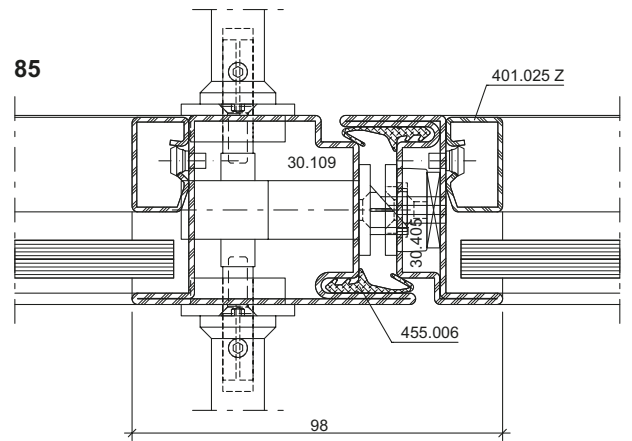
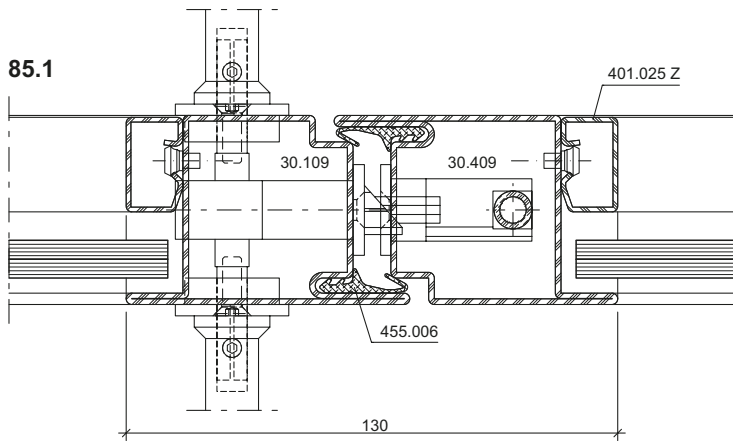

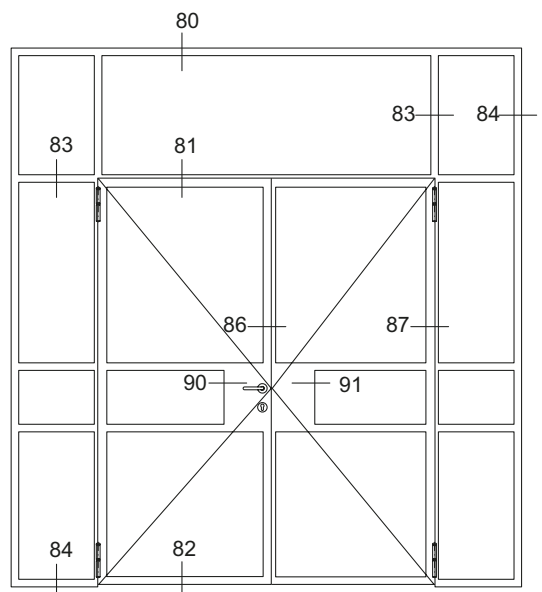
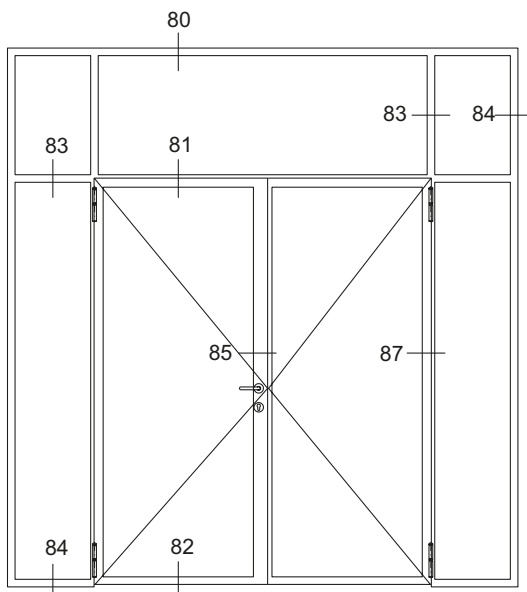
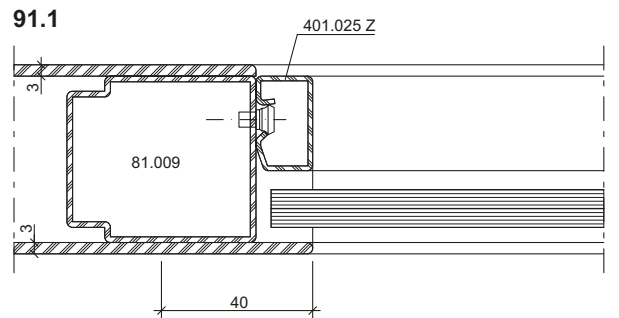
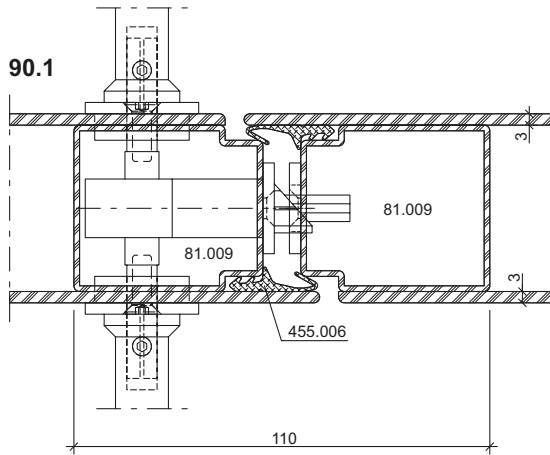
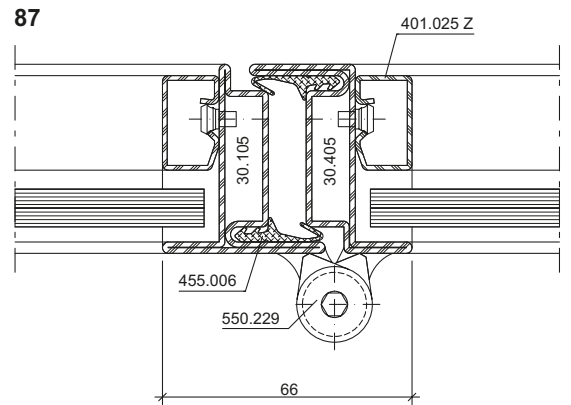
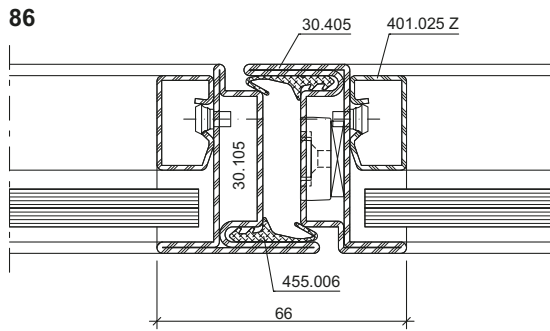

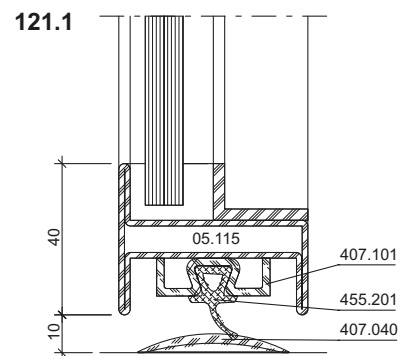
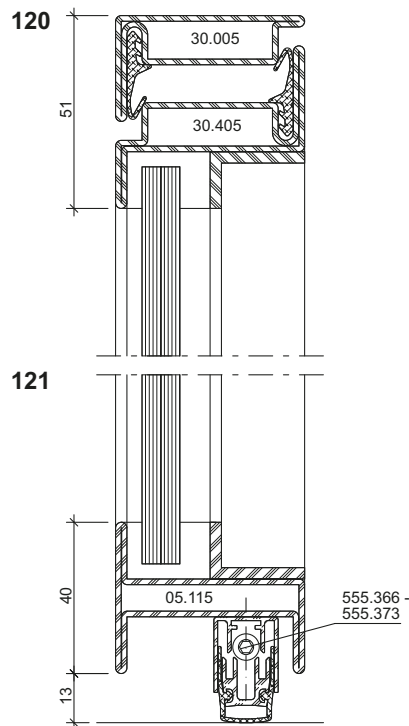
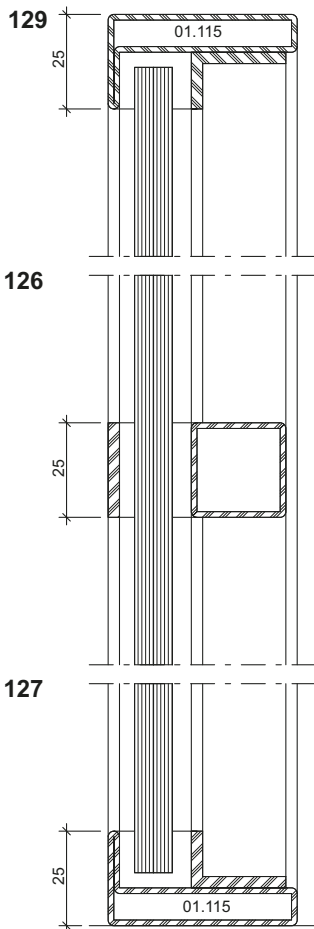
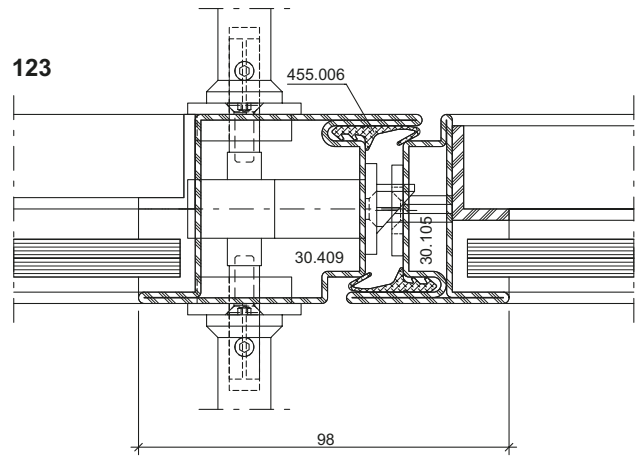
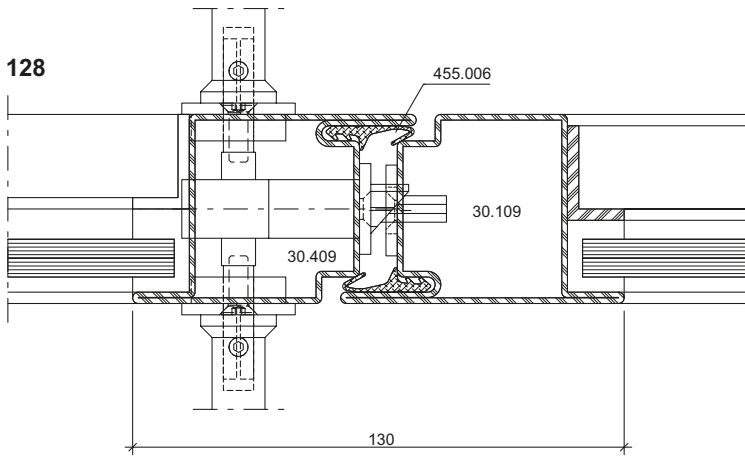

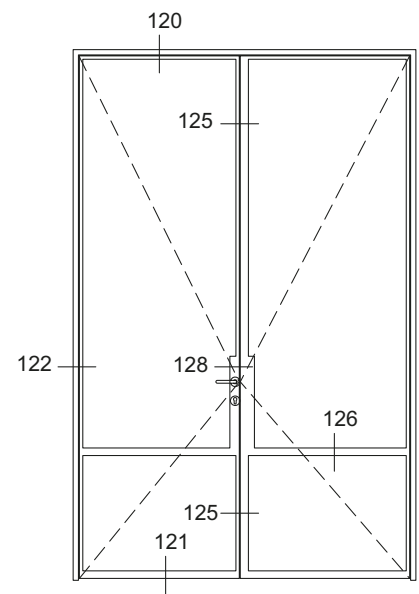
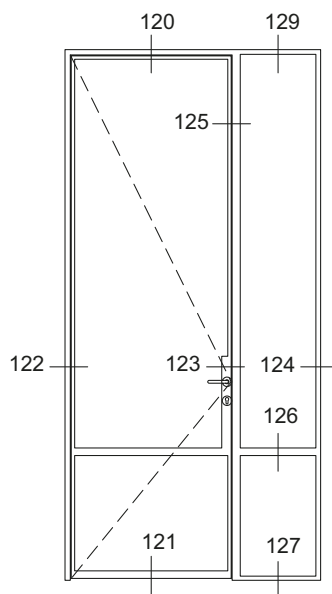
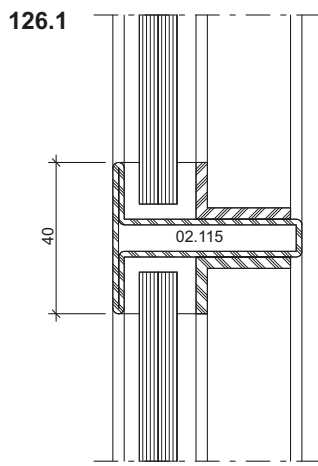
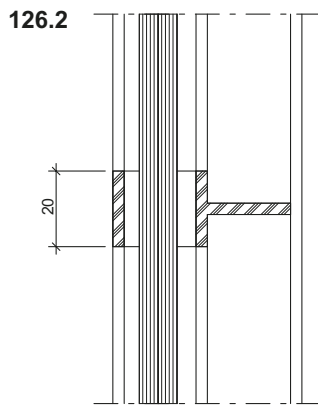
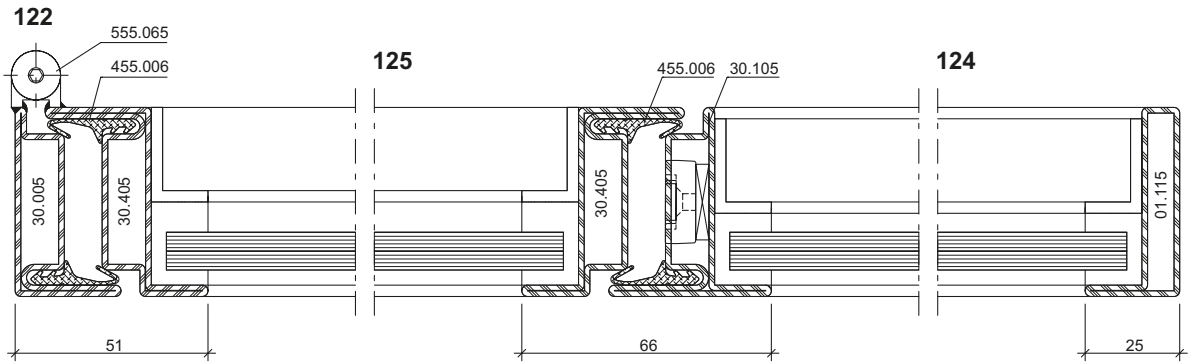

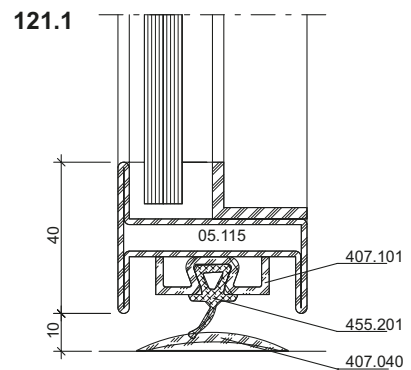
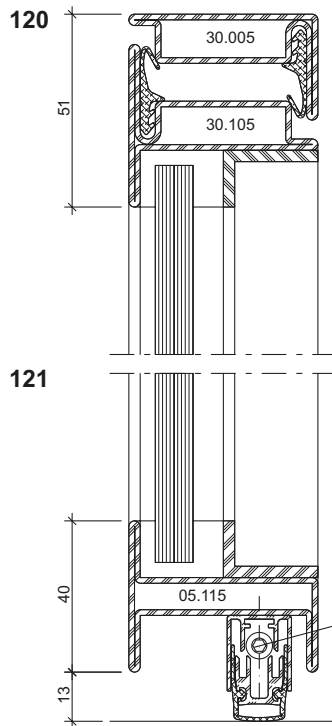
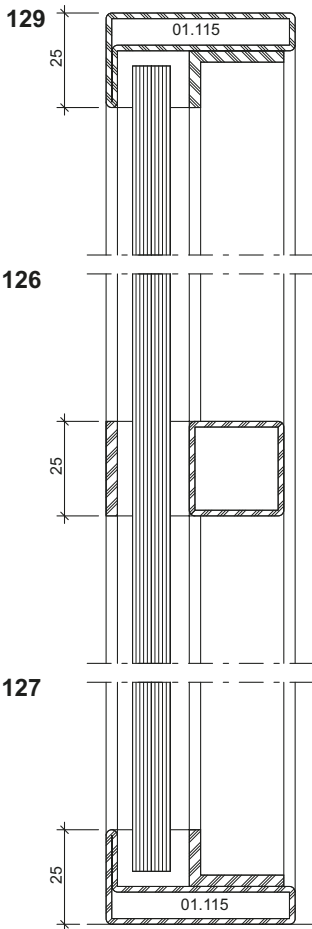
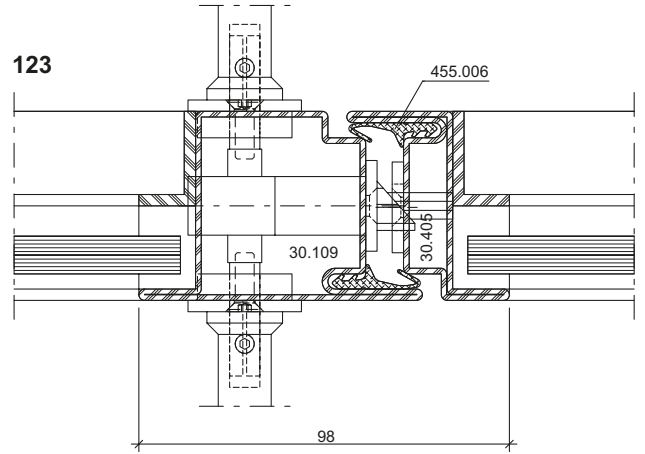
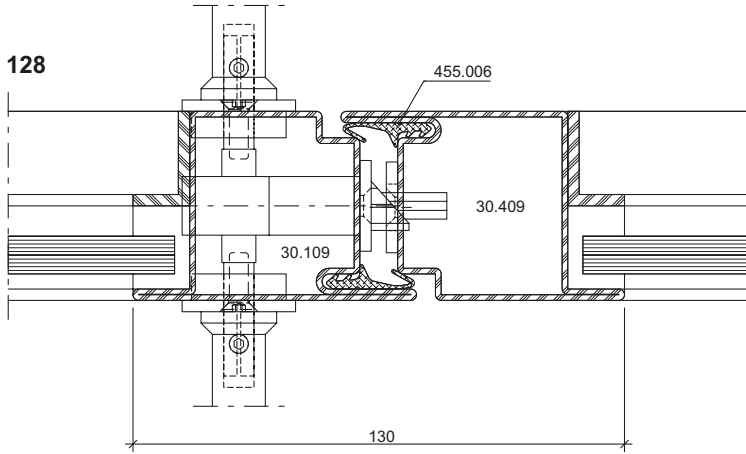

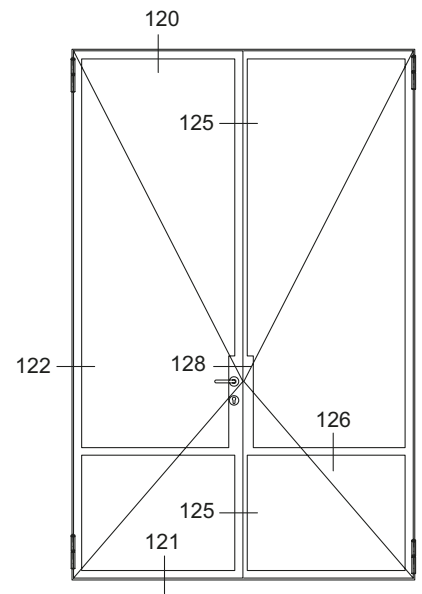
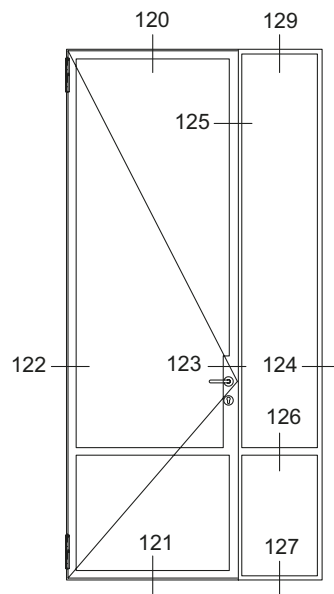
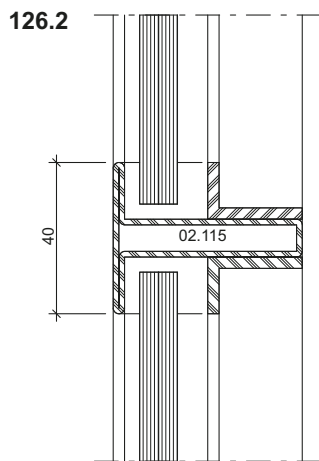
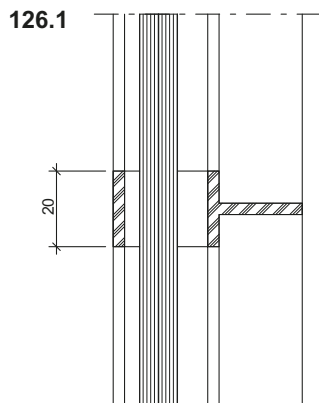
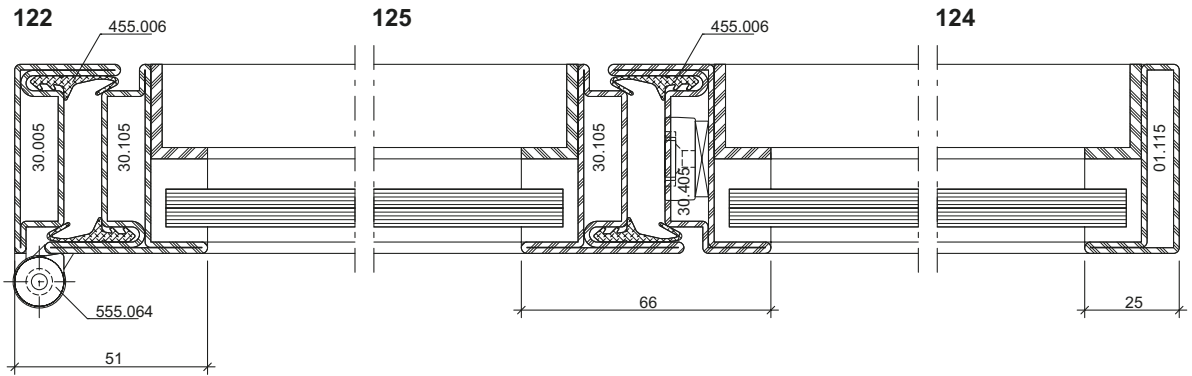

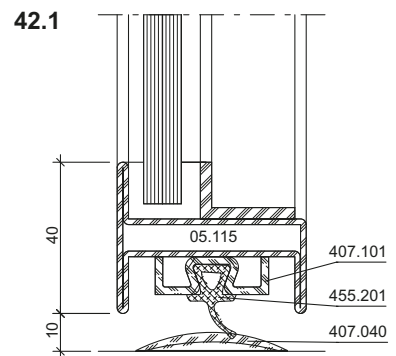
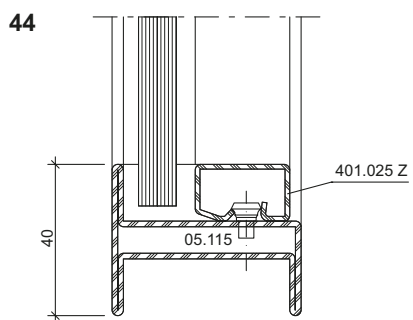
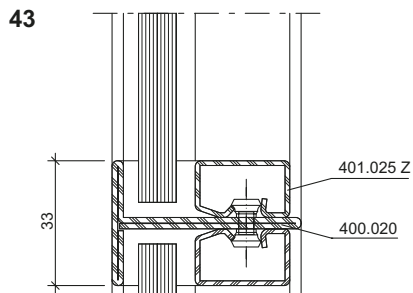
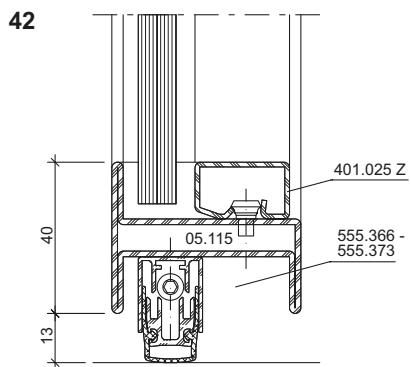
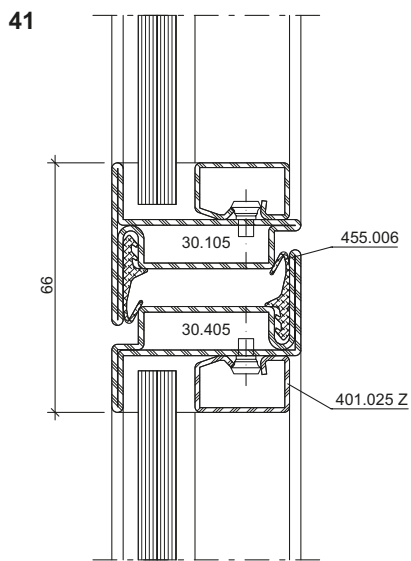
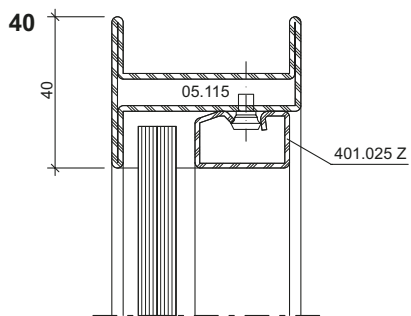

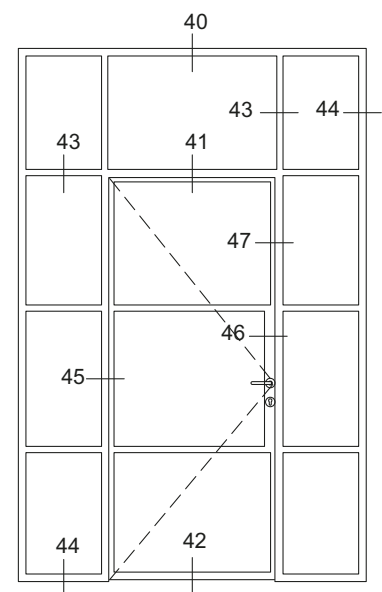
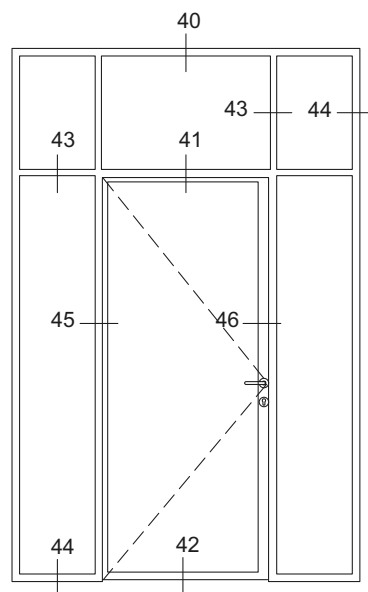
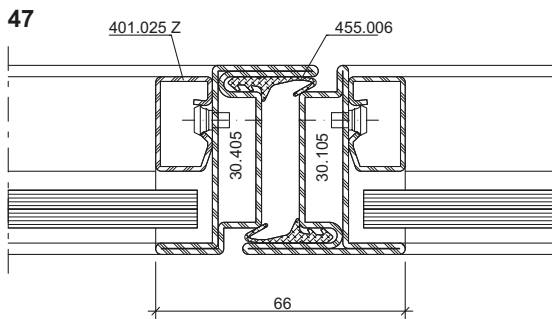
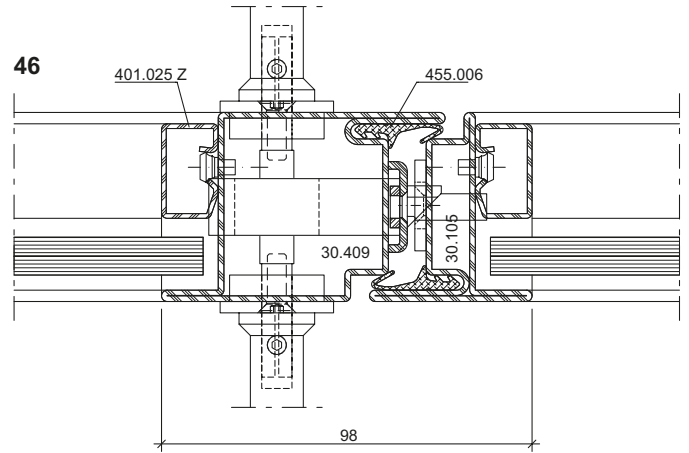
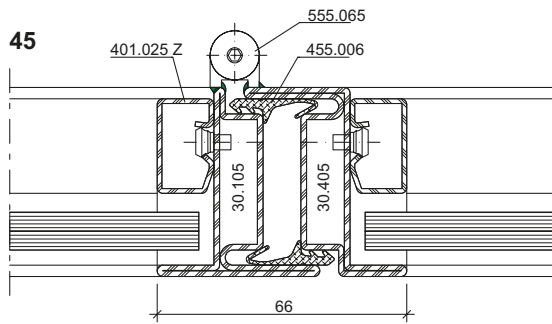

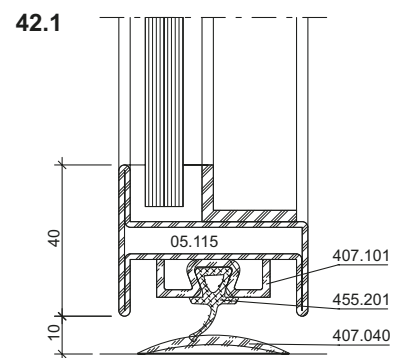
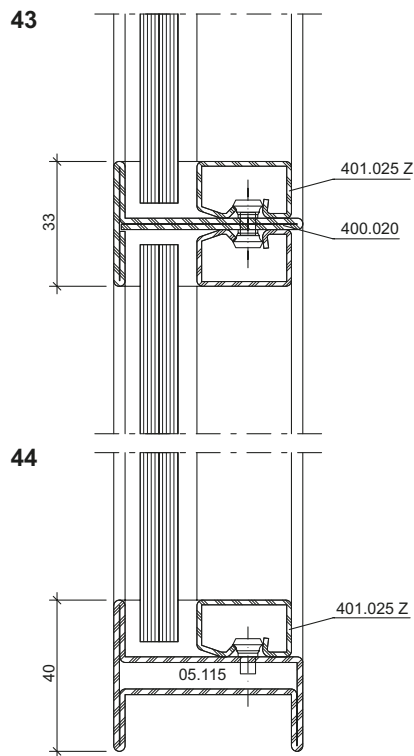
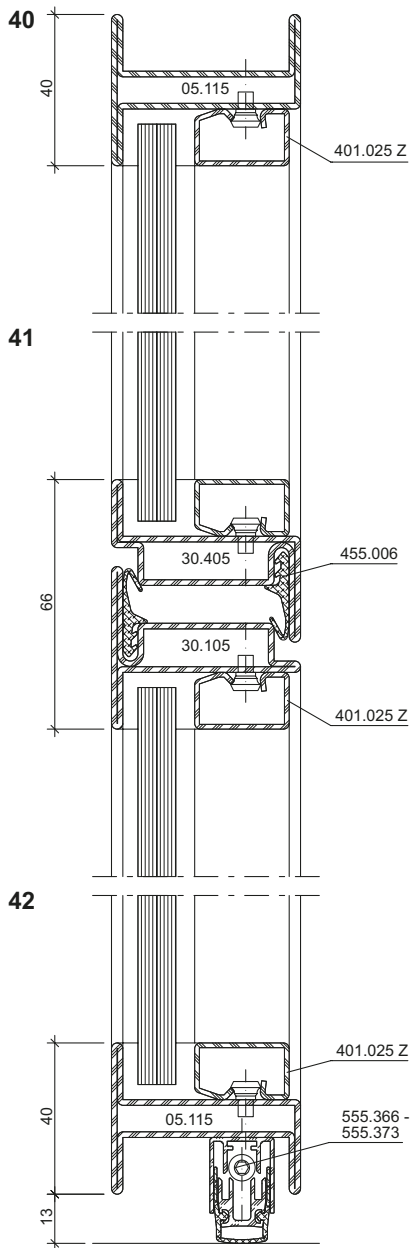

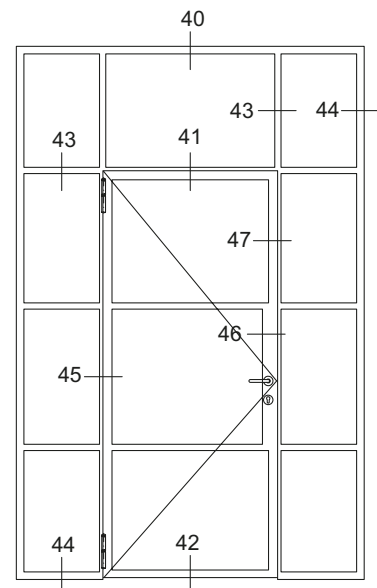
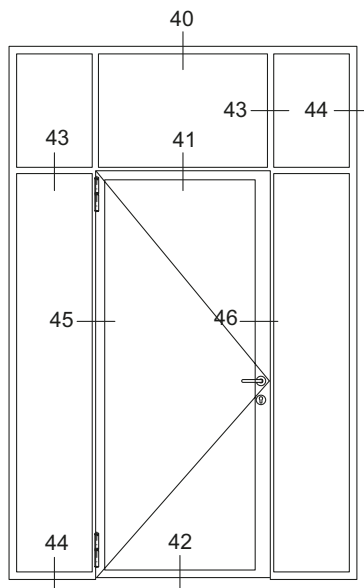
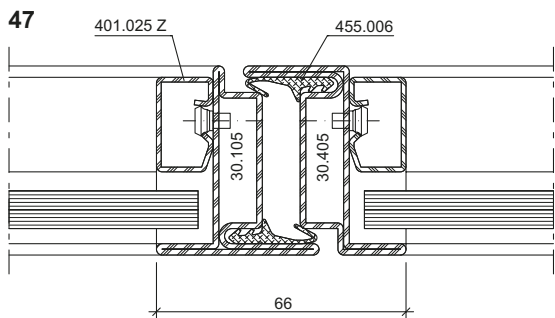
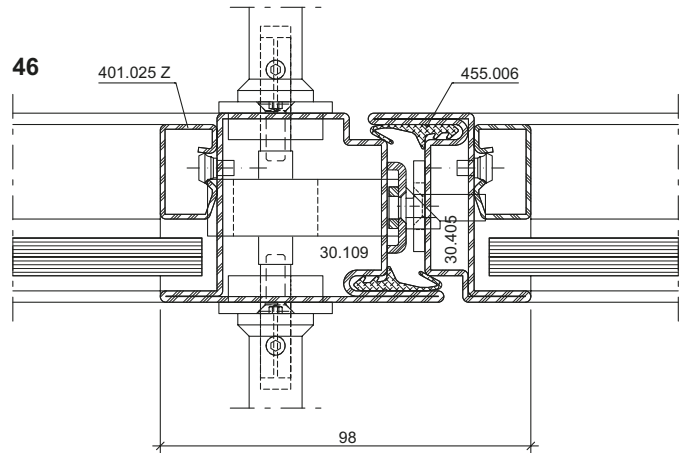
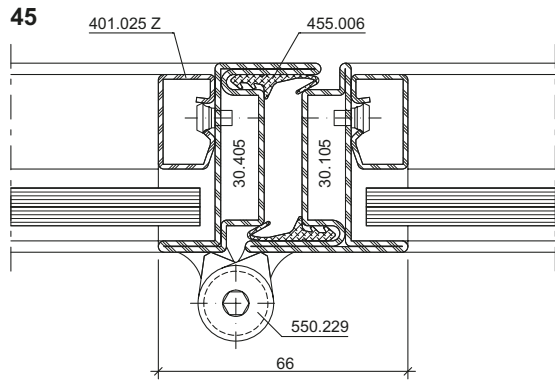

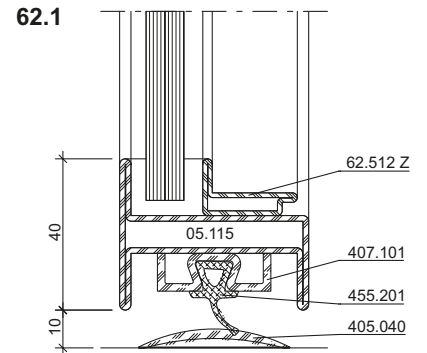
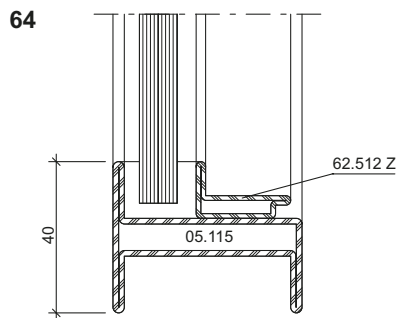
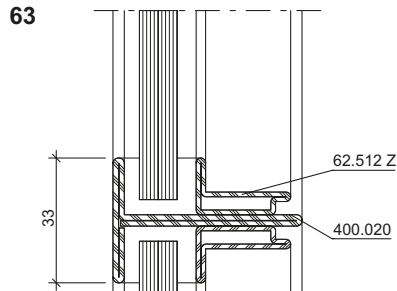
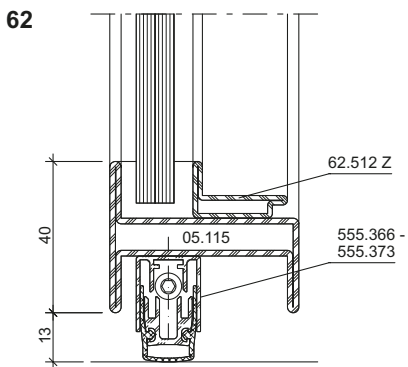
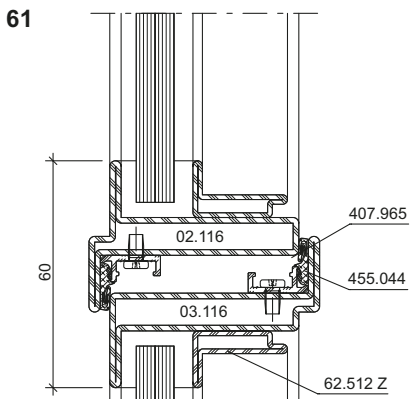
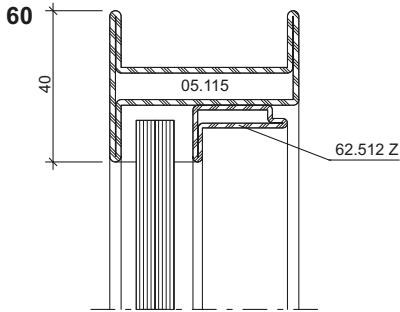
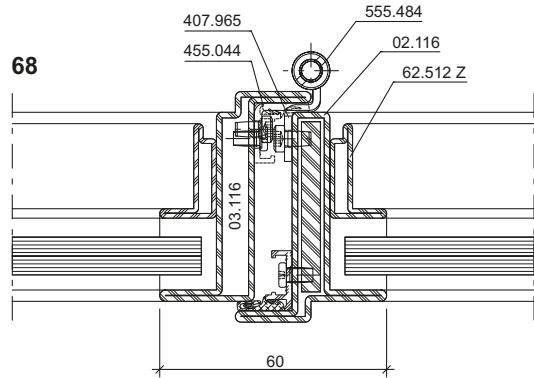
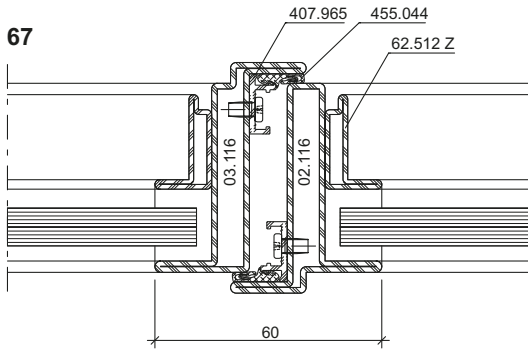

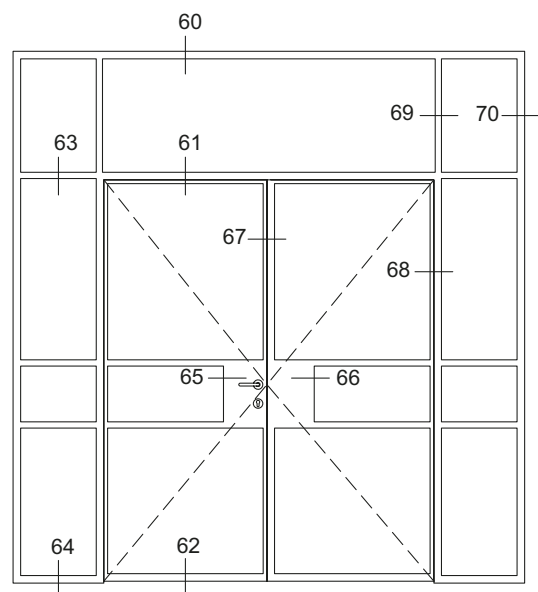
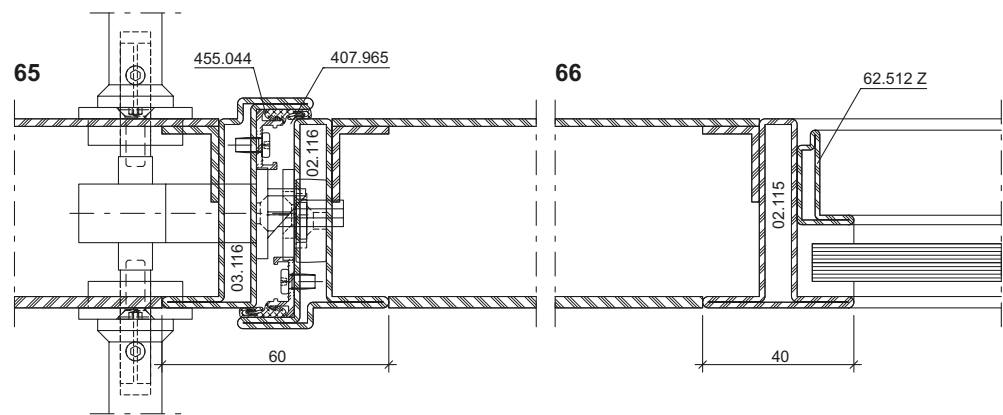
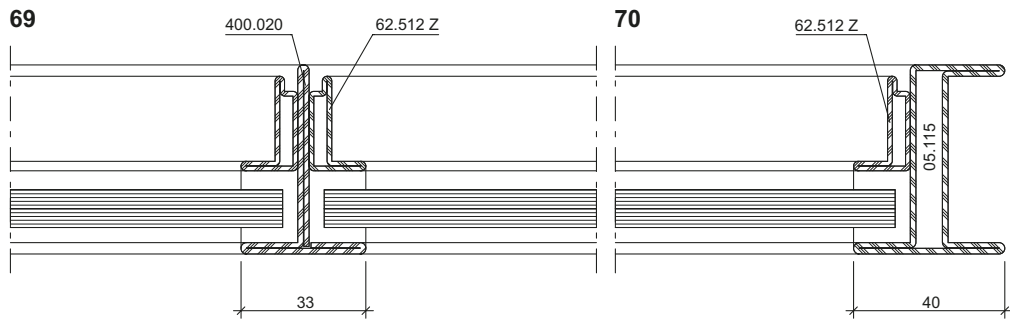

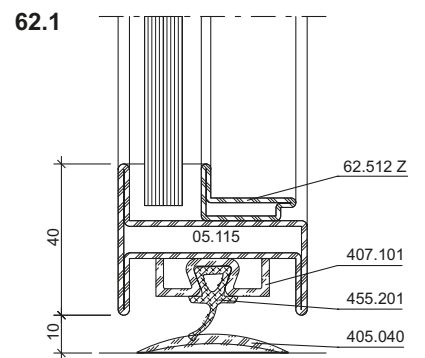
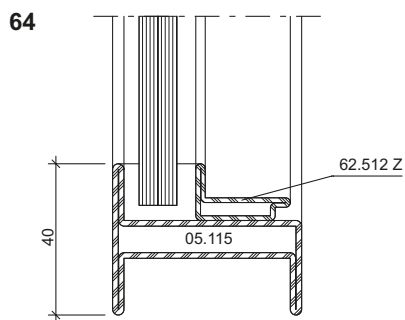
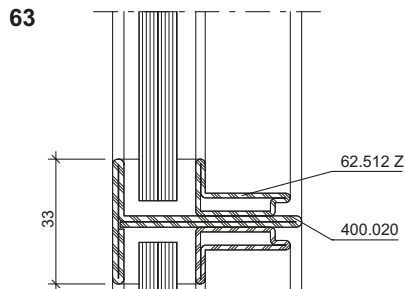
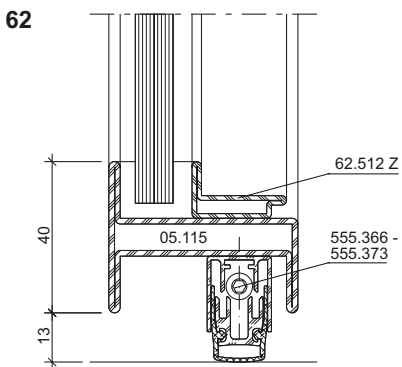
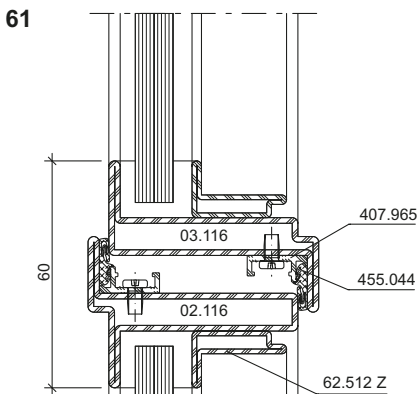
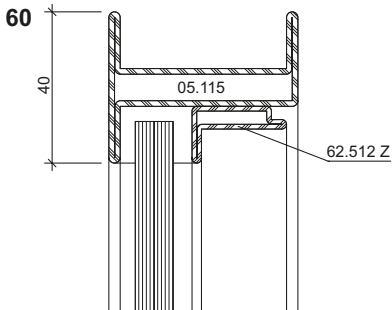
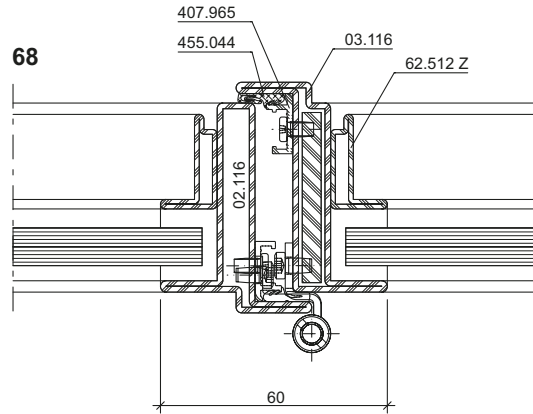
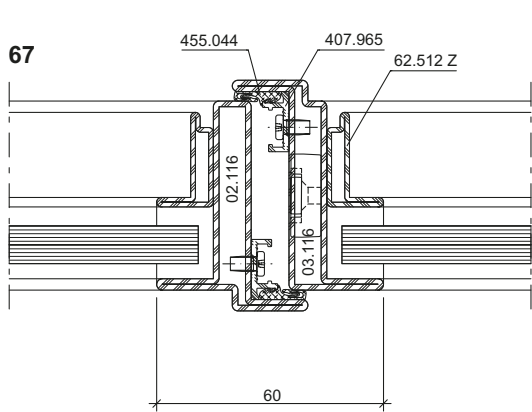

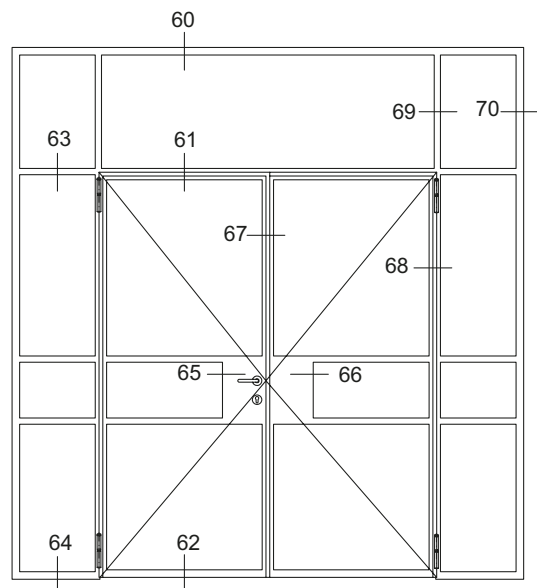
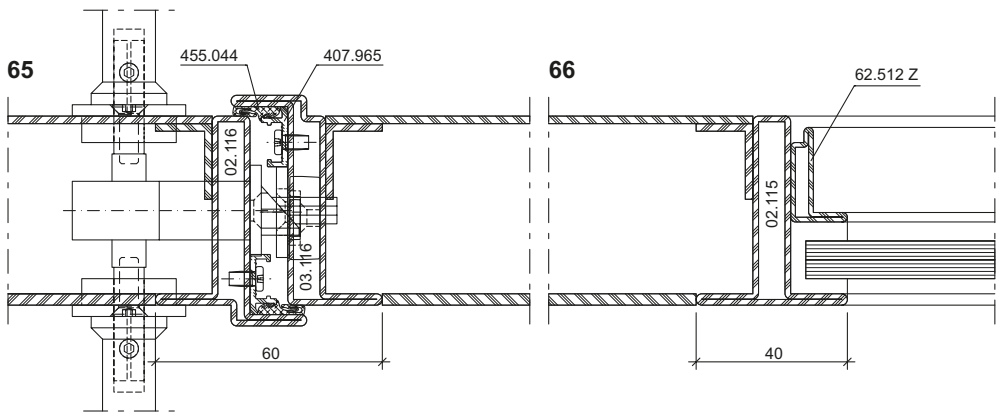
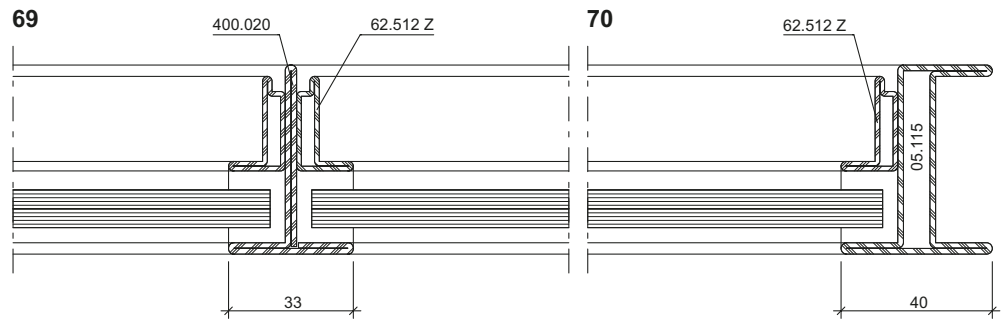

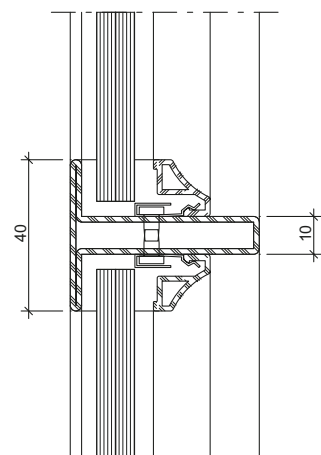
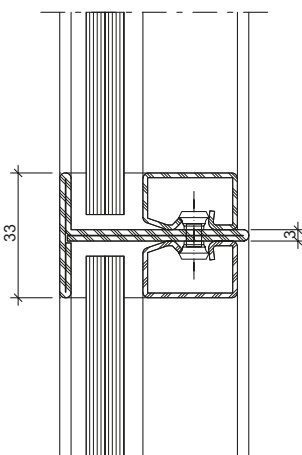
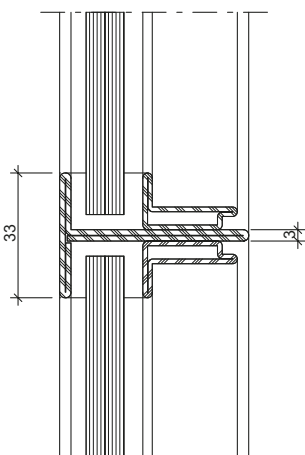
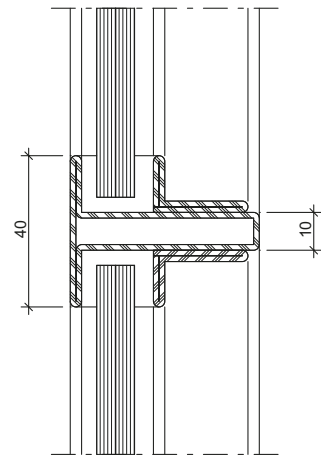
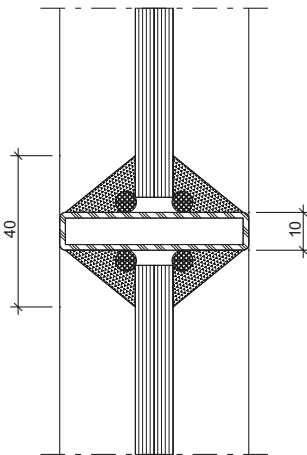
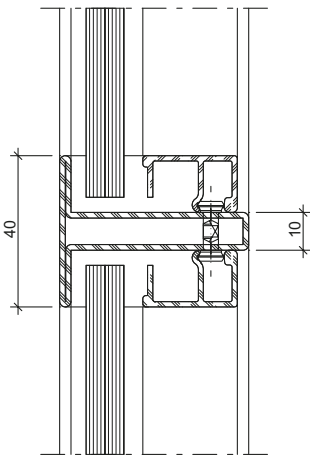
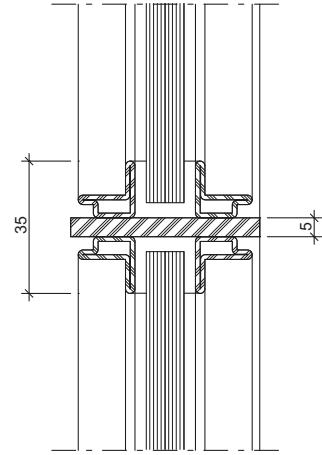
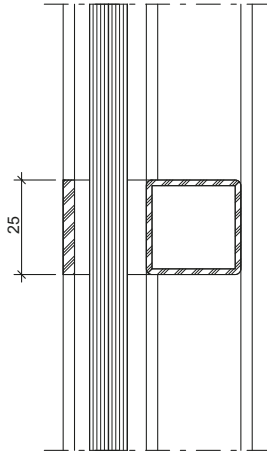
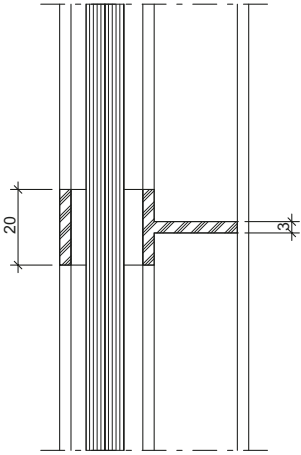

**Rahmenprofile/
 Festverglasungen**
 Ohne spezielle Massnahmen

**Profils de cadre/
 vitrages fixes**
 Sans mesures spéciales

**Frame profiles/
 fixed glazings**
 Without special measures

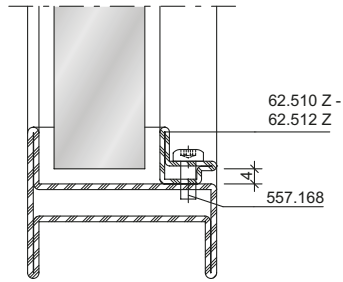
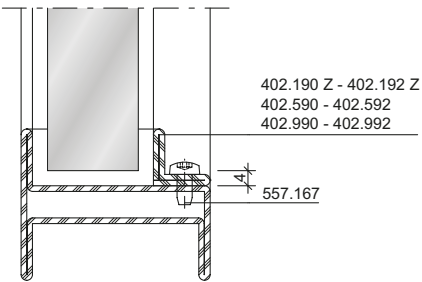
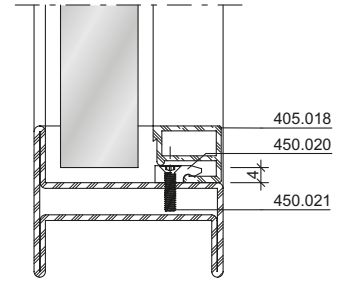
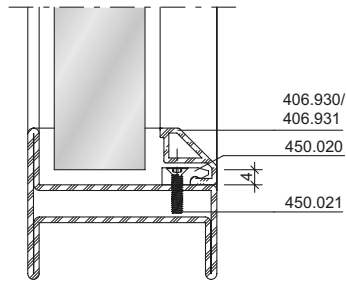
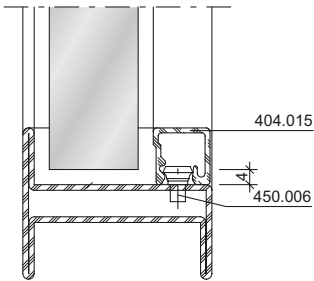
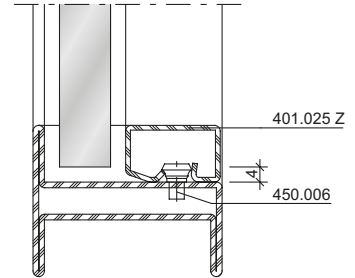
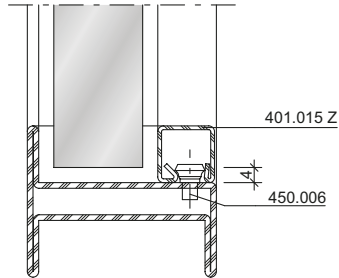
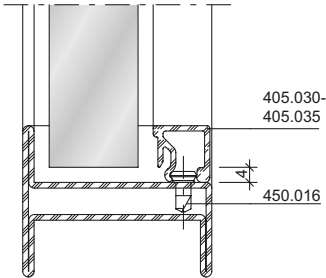

Einbausituationen Glasleisten

Situations de montage des parclozes

Installation situations for glazing beads

Jansen Art'15

Jansen Art'15

Jansen Art'15

Rahmenprofile/ Festverglasungen

Mit speziellen Massnahmen:

Glasluft 5 mm /

Glaseinstand max. 10 mm

Glasmasse zwingend tolerieren
+0/-1 mm

Profilés de cadre/ vitrages fixes

Avec mesures spéciales:

Feuillure de verre 5 mm /

Prise en feuillure max. 10 mm

Tolérer obligatoirement les dimensions
de verre +0/-1 mm

Frame profiles/ fixed glazings

With special measures:

Glazing rebate 5 mm /

Glass insertion depth max. 10 mm

Mandatory glass mass tolerance
+0/-1 mm

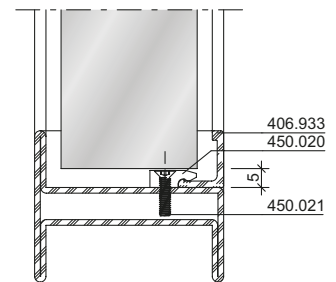
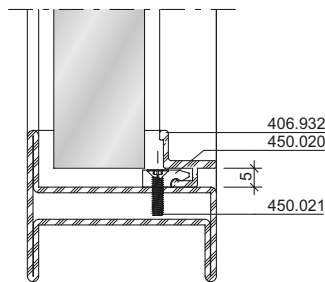
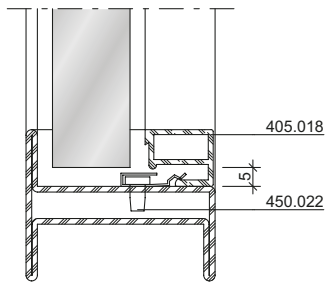
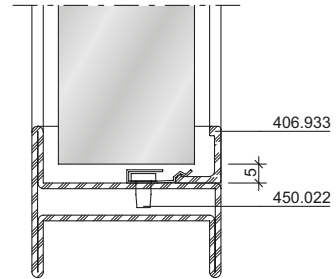
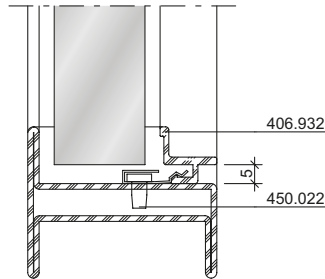
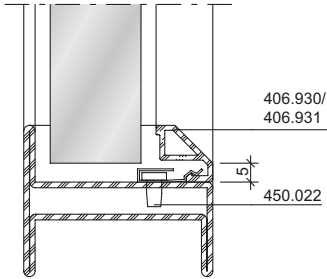

Flügelprofile Z
 Ohne spezielle Massnahmen

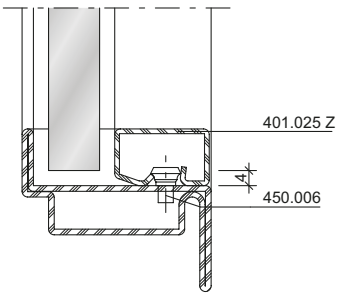

Profils de vantail Z
 Sans mesures spéciales

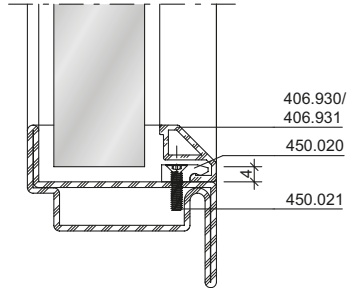

Leaf profiles Z
 Without special measures

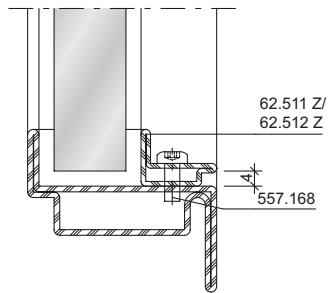
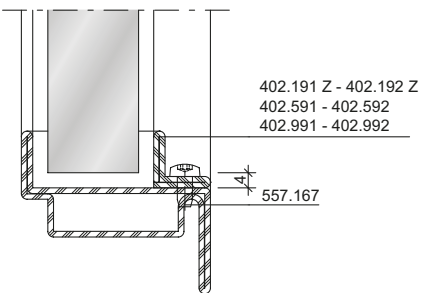
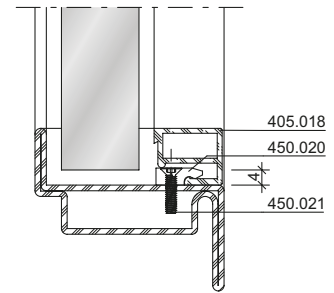

Einbausituationen Glasleisten

Situations de montage des parclozes

Installation situations for glazing beads

Jansen Art'15

Jansen Art'15

Jansen Art'15

Flügelprofile Z

Mit speziellen Massnahmen:

Glasluft 5 mm /

Glaseinstand max. 10 mm

Glasmasse zwingend tolerieren

+0/-1 mm

Profils de vantail Z

Avec mesures spéciales:

Feuillure de verre 5 mm /

Prise en feuillure max. 10 mm

Tolérer obligatoirement les dimensions

de verre +0/-1 mm

Leaf profiles Z

With special measures:

Glazing rebate 5 mm /

Glass insertion depth max. 10 mm

Mandatory glass mass tolerance

+0/-1 mm

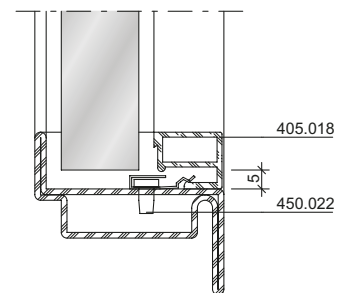
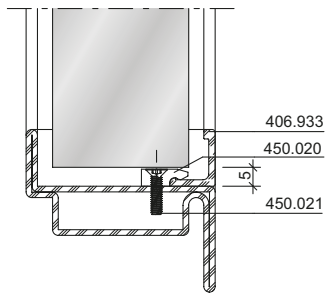
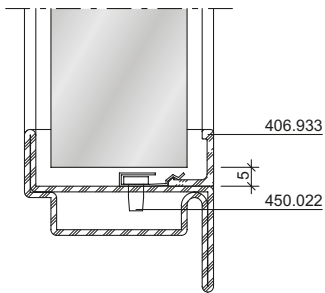
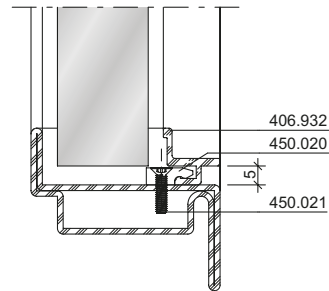
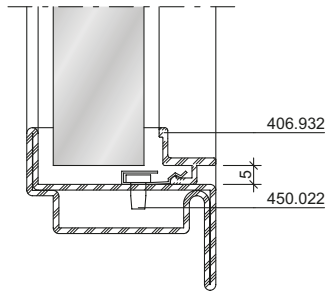
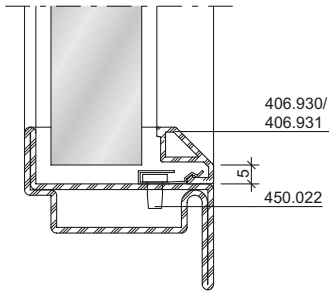

Flügelprofile Z

Mit speziellen Massnahmen:
Loch für Befestigungsknopf fräsen
oder Glasleiste min. 3 mm nach innen
versetzen

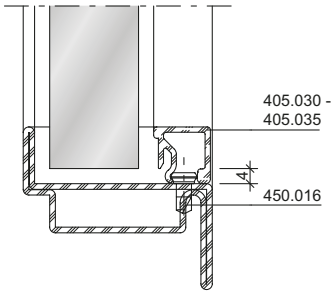

Profils de vantail Z

Avec mesures spéciales:
Fraisier un trou pour le bouton de
fixation ou déplacer la parclose vers
l'intérieur de 3 mm min.

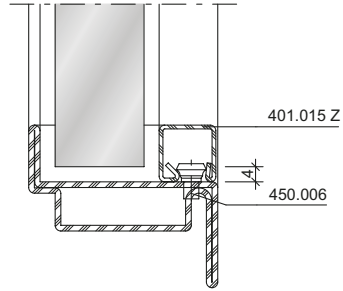

Leaf profiles Z

With special measures:
Mill hole for fastening stud or move
glazing bead inward a minimum of
3 mm

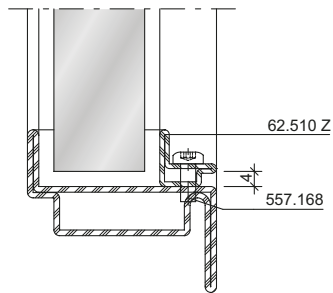
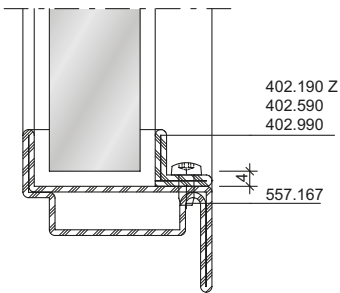
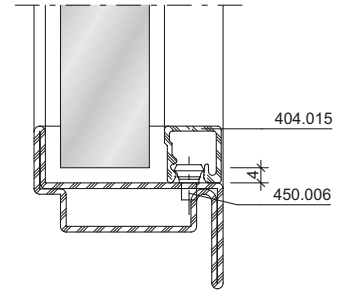

Einbausituationen Glasleisten

Situations de montage des parclozes

Installation situations for glazing beads

Jansen Art'15

Jansen Art'15

Jansen Art'15

Flügelprofile T

Ohne spezielle Massnahmen

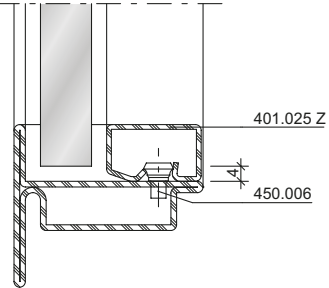

Profils de vantail T

Sans mesures spéciales

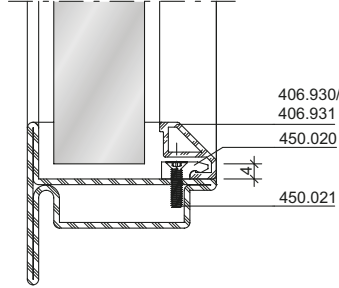

Leaf profiles T

Without special measures

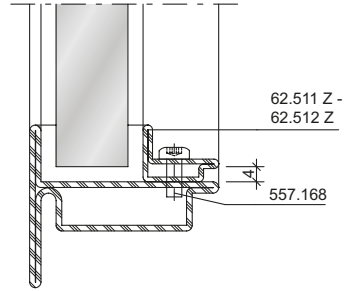
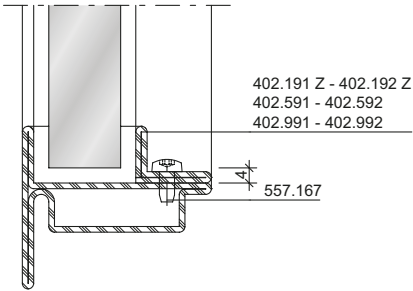
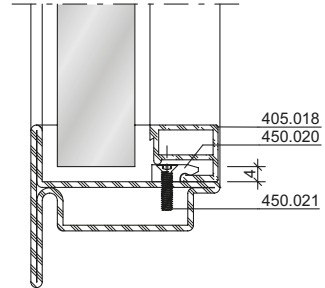

Flügelprofile T

Mit speziellen Massnahmen:
 Glasluft 5 mm /
 Glaseinstand max. 10 mm
 Glasmasse zwingend tolerieren
 +0/-1 mm

Profils de vantail T

Avec mesures spéciales:
 Feuillure de verre 5 mm /
 Prise en feuillure max. 10 mm
 Tolérer obligatoirement les dimensions
 de verre +0/-1 mm

Leaf profiles T

With special measures:
 Glazing rebate 5 mm /
 Glass insertion depth max. 10 mm
 Mandatory glass mass tolerance
 +0/-1 mm

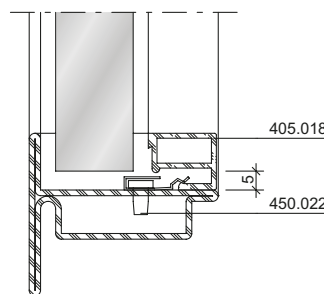
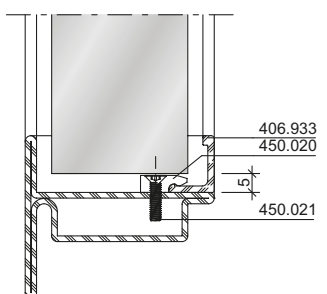
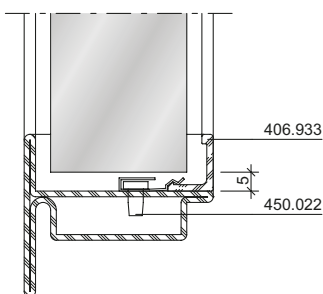
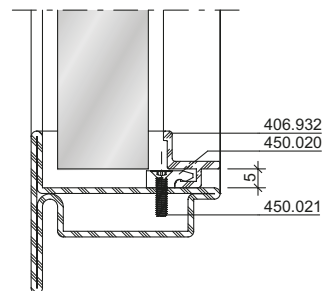
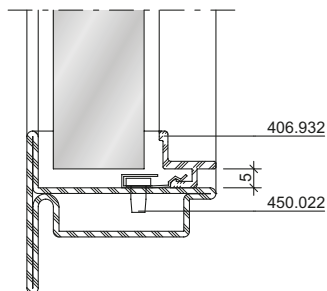
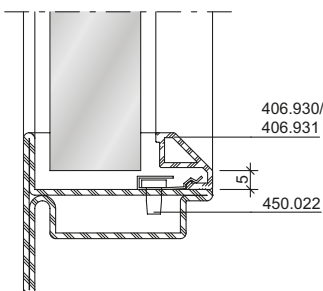

Einbausituationen Glasleisten

Situations de montage des parcloses

Installation situations for glazing beads

Jansen Art'15

Jansen Art'15

Jansen Art'15

Flügelprofile T

Mit speziellen Massnahmen:
Glasleiste min. 3 mm nach innen
versetzen

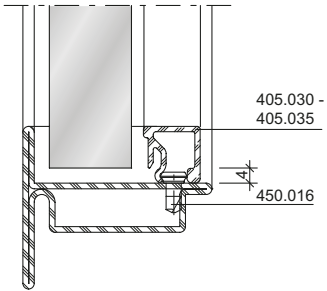

Profils de vantail T

Avec mesures spéciales:
Déplacer la parclose vers l'intérieur
de 3 mm min.

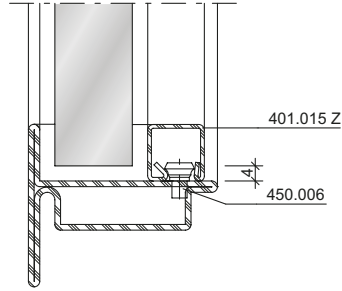

Leaf profiles T

With special measures:
Move glazing bead inward a minimum
of 3 mm

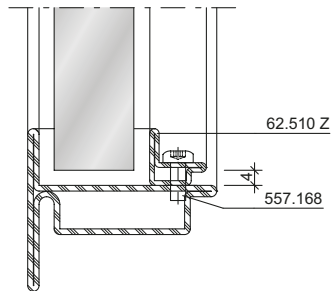
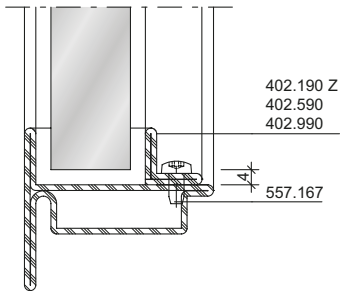
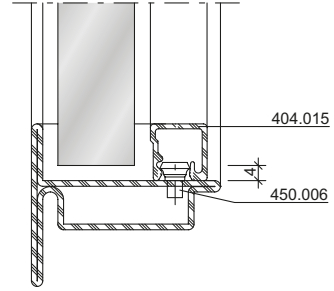

Ausbildung Türsockel

Situation du socle de porte

Construction of bottom rail

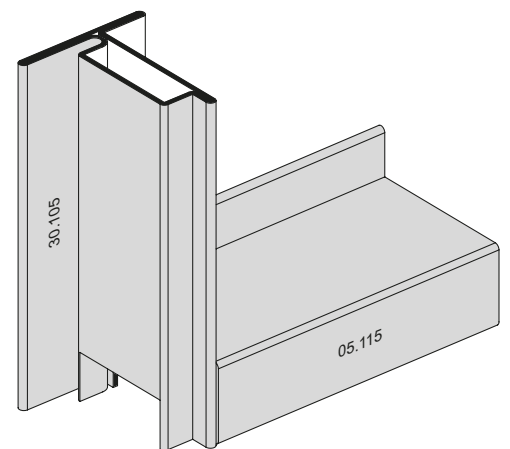
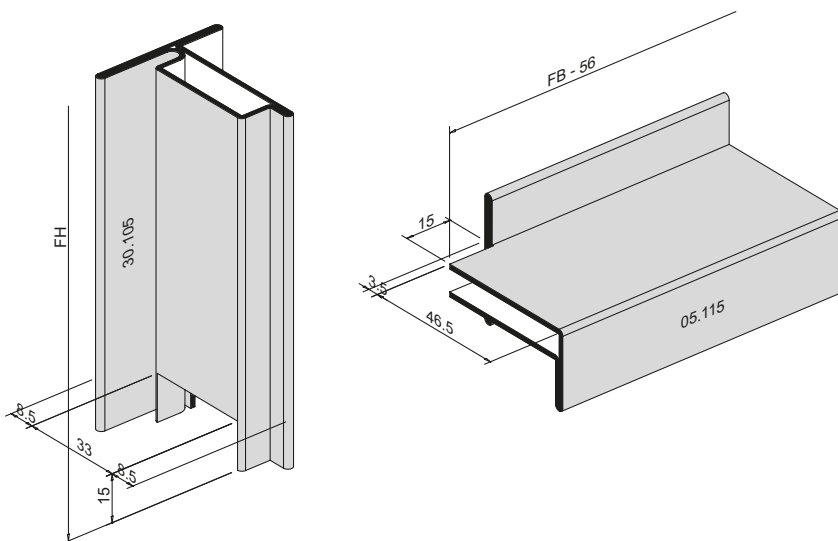
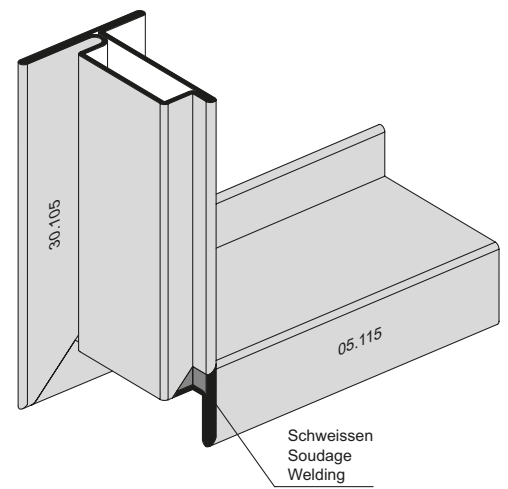
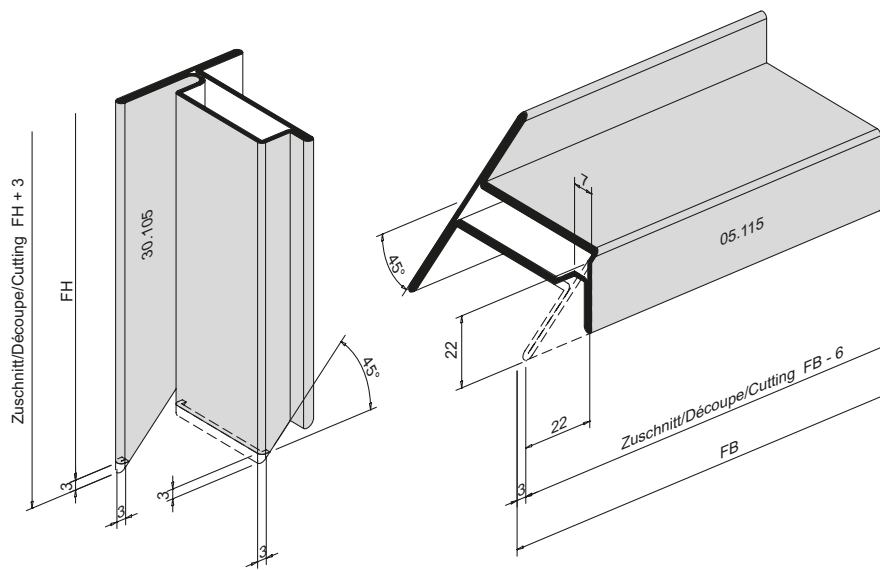
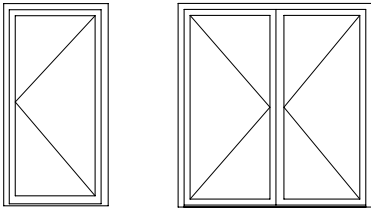

Anschraubband 557.182/557.183

Paumelle à visser 557.182/557.183

Screw-on hinge 557.182/557.183

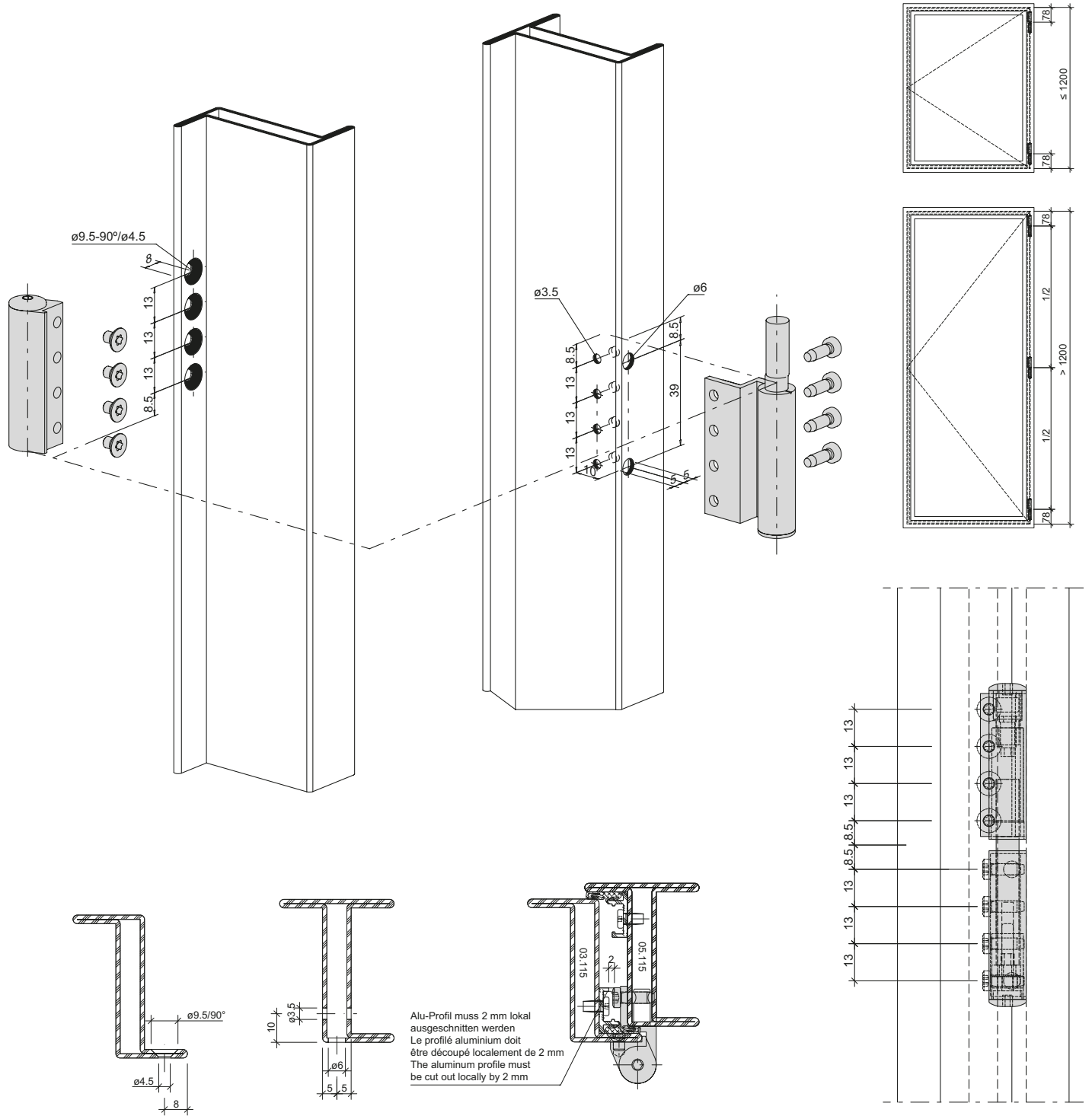



Schallschutz

Ausführungsvarianten

Die nachfolgende Typenübersicht ergibt einen Überblick über die beurteilten Varianten.

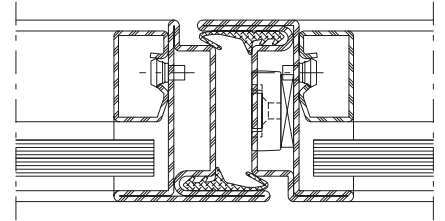
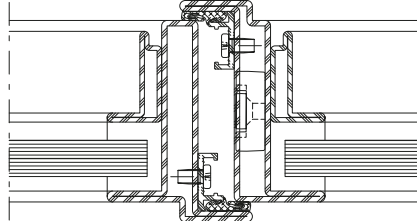
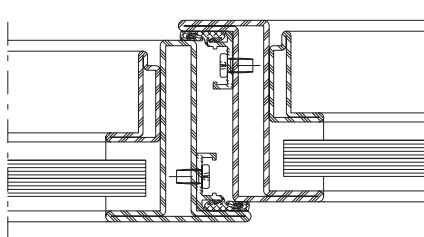
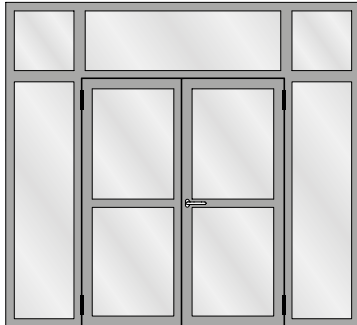
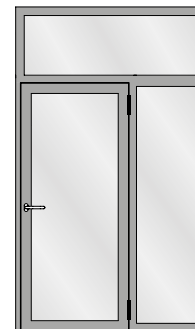
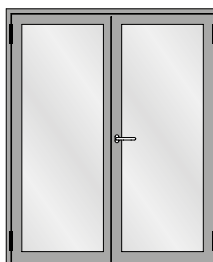
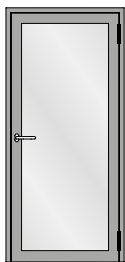

Isolation phonique

Modèles

L'aperçu des types suivant fournit une vue d'ensemble des variantes examinées.

Sound insulation

Design range

The following overview of types provides an overview of the evaluated designs.

Tabelle 8
 Tür-Wandsystem Jansen Art'15,
 bewertetes Schalldämm-Mass in
 Basisausführung

Tableau 8
 Système de porte/mur Art'5, indice
 d'affaiblissement acoustique pondère
 en version de base

Table 8
 Door/wall system Art'15, weighted
 sound reduction index in basic version

| R_w (C; Ctr) in dB | | | | | |
|--|---|---|---|---|------------------------------|
| R_w, P, Glas der Verglasung in dB | Ausführungsvariante / Variante de realisation / Design variant | | | | |
| | Tür, einflügelig, Schleiflippen-dichtung ¹⁾ | Tür, einflügelig, Absenk-dichtung (Standard ²⁾) | Tür, einflügelig, Absenk-dichtung (Schallschutz ³⁾) | Tür, einflügelig, mit vierseitiger Zarge ⁴⁾ | Wandelement, festverglast |
| R_w, P, glass du vitrage en dB | Porte, à un vantail, joint à lèvres abrasif ¹⁾ | Porte, à un vantail, joint bas de porte (Standard ²⁾) | Porte, à un vantail, joint bas de porte (isolation phonique ³⁾) | Porte, à un vantail avec dormant à quatre cotés ⁴⁾ | Élément de mur, châssis fixe |
| R_w, P, glass of glazing in dB | Door, single leaf, threshold lip seal ¹⁾ | Door, single leaf, drop-down seal (Standard ²⁾) | Door, single leaf, drop-down seal (acoustic insulation ³⁾) | Door, single leaf, with four-sided door ⁴⁾ | Wall element fixed glazed |
| 31 ⁵⁾ | 24 (-1; -1) | 29 (-1; -4) | 30 (-1; -4) | 31 (-1; -5) | 31 (-1; -5) |
| 32 | 24 (-1; -1) | 30 (-1; -4) | 31 (-1; -4) | 32 (-1; -5) | 32 (-1; -5) |
| 33 | 24 (-1; -1) | 31 (-1; -4) | 32 (-1; -4) | 33 (-1; -5) | 33 (-1; -5) |
| 34 | 24 (-1; -1) | 32 (-1; -4) | 33 (-1; -4) | 34 (-1; -5) | 34 (-1; -5) |
| 35 | 24 (-1; -1) | 32 (-1; -4) | 33 (-1; -4) | 35 (-1; -5) | 35 (-1; -5) |
| 36 | 24 (-1; -1) | 33 (-1; -4) | 34 (-1; -4) | 36 (-1; -5) | 36 (-1; -5) |
| 37 ⁶⁾ | 24 (-1; -1) | 33 (-1; -4) | 34 (-1; -4) | 36 (-1; -5) | 37 (-1; -5) |
| 38 | 24 (-1; -1) | 33 (-1; -4) | 34 (-1; -4) | 37 (-1; -5) | 37 (-1; -5) |
| 39 | 25 (-1; -1) | 34 (-1; -4) | 35 (-1; -4) | 38 (-1; -5) | 38 (-1; -5) |
| 40 | 25 (-1; -1) | 34 (-1; -4) | 35 (-1; -4) | 39 (-1; -6) | 39 (-1; -6) |
| 41 | 25 (-1; -1) | 35 (-1; -4) | 36 (-1; -4) | 40 (-1; -6) | 40 (-1; -6) |
| 42 | 25 (-1; -1) | 35 (-1; -4) | 36 (-1; -4) | 41 (-1; -6) | 41 (-1; -6) |
| 43 | 25 (-1; -1) | 35 (-1; -4) | 36 (-1; -4) | 42 (-1; -6) | 42 (-1; -6) |
| 44 | 25 (-1; -1) | 35 (-1; -4) | 36 (-1; -4) | 42 (-1; -6) | 42 (-1; -6) |
| 45 ⁷⁾ | 25 (-1; -1) | 35 (-1; -4) | 36 (-1; -4) | 42 (-1; -6) | 43 (-2; -7) |
| 46 | 25 (-1; -1) | 35 (-1; -4) | 36 (-1; -4) | 42 (-1; -6) | 43 (-2; -7) |
| 47 | 25 (-1; 1) | 36 (-1; -4) | 37 (-1; -4) | 43 (-1; -6) | 44 (-2; -7) |
| 48 | 25 (-1; 1) | 36 (-1; -4) | 37 (-1; -4) | 43 (-1; -6) | 44 (-2; -7) |
| 49 ⁸⁾ | 25 (-1; 1) | 36 (-1; -3) | 37 (-1; -3) | 43 (-1; -6) | 44 (-2; -7) |

Leistungseigenschaften nach EN 14351-1

Caractéristiques de performance selon EN 14351-1

Performance characteristics according to EN 14351-1

Jansen Art'15

Jansen Art'15

Jansen Art'15

- 1) gerundete Schwelle und Schleiflippendichtung
- 2) ebene Schwelle und Absenkndichtung (geklebt)
- 3) ebene Schwelle und Absenkndichtung (geklebt, Einbau mit Passleiste, Bodenluft reduziert)
- 4) vierseitige Zarge und umlaufende Falzdichtungen
- 5) Standardverglasung 4/16/4
- 6) Standardverglasung 8 VSG (Akustikfolie)
- 7) Standardverglasung 10/16/8 VSG (Akustikfolie)
- 8) Standardverglasung 12VSG/16/8 VSG (Akustikfolie)

- 1) Seuil arrondi et joint à lèvre abrasif
- 2) Seuil plan et joint bas de porte (collé)
- 3) Seuil plan et joint bas de porte (collé, montage avec liteau ajustage, passage d'air au sol réduit)
- 4) Dormant à quatre cotés et joints d'étanchéité périphériques
- 5) Vitrage standard 4/16/4
- 6) Vitrage standard 8 VSG (film acoustique)
- 7) Vitrage standard 10/16/8 VSG (film acoustique)
- 8) Vitrage standard 12VSG/16/8 VSG (film acoustique)

- 1) Rounded threshold and threshold lip seal
- 2) Level threshold and drop-down seal (bonded)
- 3) Level threshold and drop-down seal (bonded, Installation with fitting strip, air gap reduced)
- 4) Four-sided door frame and surrounding rebate seals
- 5) Standard glazing 4/16/4
- 6) Standard glazing 8 LSG (acoustic film)
- 7) Standard glazing 10/16/8 LSG (acoustic film)
- 8) Standard glazing 12LSG/16/8 LSG (acoustic film)



Tabelle 9
 Tür-Wandsystem Jansen Art'15,
 bewertetes Schalldämm-Mass in
 Ausführungsvarianten

Tableau 9
 Système de porte/mur Art'15, indice
 d'affaiblissement acoustique pondère
 en variantes de conception

Table 9
 Door/wall system Art'15, weighted
 sound reduction index in design
 variants

| R_w (C; Ctr) in dB | | | | | | | | | |
|---|--|--|--|---|---|---|---|---|----|
| R_w der Ausführungs- variante gemäß Tabelle 8 in dB R_w de la variante de réalisation selon le tableau 8 en dB R_w of design variant according to Table 8 in dB | Abzugswert ΔR_w in dB / Valeur de déduction ΔR_w en dB / Deduction value ΔR_w in dB | | | | | | | | |
| | Rahmen- anteil ¹⁾ 25% $\leq p \leq 35\%$ Part afférente au châssis ¹⁾ 25% $\leq p \leq 35\%$ Share of frame profile ¹⁾ 25% $\leq p \leq 35\%$ | Rahmen- anteil ¹⁾ $p > 35\%$ Part afférente au châssis ¹⁾ $p > 35\%$ Share of frame profile ¹⁾ $p > 35\%$ | Zweiflügelige Tür Porte à deux vantaux Double leaf door | Anschraub- bänder ²⁾ Paumelles à visser ²⁾ Screw on hinges ²⁾ | Glasfläche ³⁾ $\leq 0,4 \text{ m}^2$ Surface de vitre ³⁾ $\leq 0,4 \text{ m}^2$ Glass surface ³⁾ $\leq 0,4 \text{ m}^2$ | Glasfläche ³⁾ $\geq 2,1 \text{ m}^2$ Surface de vitre ³⁾ $\geq 2,1 \text{ m}^2$ Glass surface ³⁾ $\geq 2,1 \text{ m}^2$ | Glasfläche ³⁾ $\geq 2,8 \text{ m}^2$ Surface de vitre ³⁾ $\geq 2,8 \text{ m}^2$ Glass surface ³⁾ $\geq 2,8 \text{ m}^2$ | Glasfläche ³⁾ $\geq 3,7 \text{ m}^2$ Surface de vitre ³⁾ $\geq 3,7 \text{ m}^2$ Glass surface ³⁾ $\geq 3,7 \text{ m}^2$ | |
| | ≥ 24 | 0 | 0 | 0 | 0 | 0 | -1 | -2 | -3 |
| | 25 | 0 | 0 | 0 | 0 | 0 | -1 | -2 | -3 |
| 26 | 0 | 0 | 0 | 0 | 0 | -1 | -2 | -3 | |
| 27 | 0 | 0 | 0 | 0 | 0 | -1 | -2 | -3 | |
| 28 | 0 | 0 | 0 | 0 | 0 | -1 | -2 | -3 | |
| 29 | 0 | 0 | 0 | 0 | 0 | -1 | -2 | -3 | |
| 30 | 0 | 0 | -1 | 0 | 0 | -1 | -2 | -3 | |
| 31 | 0 | 0 | -1 | 0 | 0 | -1 | -2 | -3 | |
| 32 | 0 | 0 | -1 | 0 | 0 | -1 | -2 | -3 | |
| 33 | 0 | 0 | -1 | 0 | 0 | -1 | -2 | -3 | |
| 34 | 0 | 0 | -1 | 0 | 0 | -1 | -2 | -3 | |
| 35 | 0 | 0 | -1 | 0 | 0 | -1 | -2 | -3 | |
| 36 | 0 | 0 | -1 | 0 | 0 | -1 | -2 | -3 | |
| 37 | 0 | 0 | -1 | 0 | 0 | -1 | -2 | -3 | |
| 38 | 0 | 0 | -1 | 0 | 0 | -1 | -2 | -3 | |
| 39 | 0 | -1 | -1 | 0 | -1 | -1 | -2 | -3 | |
| 40 | 0 | -1 | -1 | 0 | -1 | -1 | -2 | -3 | |
| 41 | 0 | -1 | -1 | 0 | -2 | -1 | -2 | -3 | |
| 42 | -1 | -2 | -2 | 0 | -2 | -1 | -2 | -3 | |
| 43 | -1 | -2 | -2 | 0 | -2 | -1 | -2 | -3 | |
| 44 | -1 | -2 | -2 | -1 | -3 | -1 | -2 | -3 | |

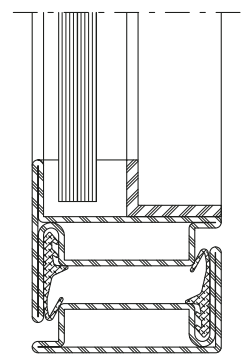
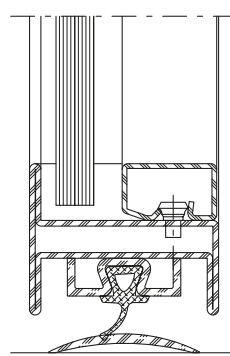
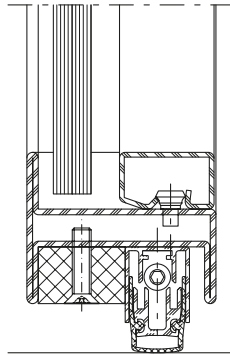
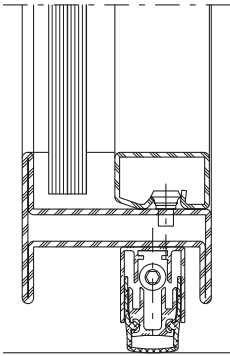
- 1) Der Rahmenanteil p ergibt sich aus der Gesamtfläche A_{ges} des Elements (Rahmenaußenmaß) und der sichtbaren Scheibengröße A_{glas} (Summe aller sichtbaren Glasflächen):

$$p = 100 \times (A_{ges} - A_{glas}) / A_{ges}$$
- 2) Anschraubband mit dichtungsunterbrechendem Lappen
- 3) Abzugswert bei Elementen mit Einzelscheiben mit einer Glasfläche außerhalb der angegebenen Grenze. Die Korrektur gilt auch für Konstruktionen mit glasteilenden Sprossen (verfügbare Glasabmessungen 0,16 m² bis 5,2 m²)

- 1) La proportion de cadre p résulte de la surface totale A_{tot} de l'élément (dimension extérieure du cadre) et de la taille de la vitre visible A_{verre} (somme de toutes les surfaces vitrées visibles):

$$p = 100 \times (A_{tot} - A_{verre}) / A_{tot}$$
- 2) Paumelle à visser avec languette d'interruption du joint
- 3) Valeur de déduction pour les éléments composés de plusieurs vitres distinctes dont la surface vitrée ne respecte pas la limite spécifiée. La correction s'applique également aux constructions dotées de petit bois (dimensions de vitre disponibles de 0,16 m² à 5,2 m²)

- 1) The share of the frame profile p results from the total area A_{total} of the element (overall frame dimension) and the visible pane size A_{glass} (sum of all visible glass surfaces): $p = 100 \times (A_{total} - A_{glass}) / A_{total}$
- 2) Screw-on hinge casement gasket interrupted in area of flap
- 3) Deduction value for elements with single panes with a glass area outside the specified limit. The correction also applies to constructions with glass dividing bars (available glass dimensions 0.16 m² to 5.2 m²)

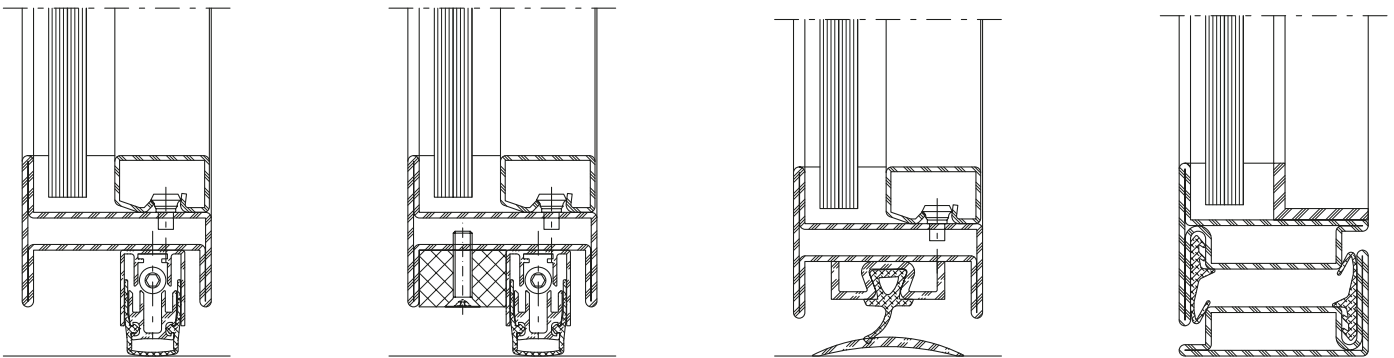

Jansen Art'15
Jansen Art'15
Jansen Art'15

**Lieferprogramm
Jansen Art'15**

Code A = Änderungen
Code E = Ergänzungen
Code R = Redaktionelle Korrektur
Code T = Technische Korrektur

Version 06/2021
Artikelnummer K1179474

**Programme de livraison
Jansen Art'15**

Code A = Modifications
Code E = Compléments
Code R = Correction rédactionnelle
Code T = Correction technique

Version 06/2021
Numéro d'article K1179474

**Sales range
Jansen Art'15**

Code A = Modifications
Code E = Supplements
Code R = Editorial correction
Code T = Technical correction

Version 06/2021
Item number K1179474

| Seite Page Page | Code Code Code | Datum Date Date | Erläuterung Explication Explanation |
|-----------------------|----------------------|-----------------------|--|
| 45 | A | 06/2023 | Anpassung VE-Inhalt Art. 450.092 Adaptation du contenu UV Art. 450.092 Adaptation of PU content Art. 450.092 |
| 45 | A | 06/2023 | Anpassung VE-Inhalt Art. 450.106 Adaptation du contenu UV Art. 450.106 Adaptation of PU content Art. 450.106 |
| 28-38 | E/T | 02/2022 | Einbausituationen Glasleisten Situations de montage des parclozes Installation situations for glazing beads |
| 8/17 | A/R | 12/2021 | Artikelnummer korrigiert Numéro d'article corrigé Item number corrected |
| 22-27 77-83 | E/T | 12/2021 | Einbausituationen Glasleisten Situations de montage des parclozes Installation situations for glazing beads |

Grafische Planungsdaten wie z.B. Anwendungsbeispiele, Konstruktionsdetails, Anschlüsse am Bau, die in unseren physischen oder elektronischen Dokumentationsunterlagen enthalten sind, sind schematische Darstellungen. Gleiches gilt für digitale Medien wie CAD Dateien oder BIM Modelle.

Sie sollen den ausführenden Metallbauer und/oder Fachplaner bei der Planung und Ausführung eines Projektes unterstützen. Sie sind im konkreten Anwendungsfall durch den ausführenden Metallbauer und/oder Fachplaner auf die Verwendbarkeit im konkreten betroffenen Projekt hinsichtlich rechtlichen/regulatorischen aber auch technischen objektspezifischen Anforderungen zu überprüfen und ggfs. eigenverantwortlich anzupassen.

Bei der Überprüfung, der spezifischen Planung und der Umsetzung sind die objektspezifischen Rahmenbedingungen (Material der Bausubstanz, Dimension des Einbauelements, Farbe, Exposition, Lasteinwirkung, etc.) sowie der geltende Stand der Technik einschliesslich aller anwendbaren Normen und technischen Richtlinien eigenverantwortlich zu beachten.

Falls das vorliegende Dokument Differenzen zur aktuellen deutschen Version (Artikel Nr. K1179474) aufweist, gilt in jedem Fall der deutsche Originaltext in der jeweils geltenden Fassung im Jansen Docu Center.

Alle Ausführungen dieser Dokumentation haben wir sorgfältig und nach bestem Wissen zusammengestellt. Wir können aber keine Verantwortung für die Benutzung der vermittelten Vorschläge und Daten übernehmen. Wir behalten uns technische Änderungen ohne Vorankündigung vor.

Les données de planification graphiques, comme les exemples d'application, détails de construction et raccordements au bâtiment, fournies dans notre documentation physique et numérique sont des représentations schématiques. Il en va de même pour les médias numériques comme les fichiers CAD ou modèles BIM.

Leur but est de faciliter la planification et réalisation d'un projet par les constructeurs métalliques et/ou concepteurs. Concrètement, elles doivent être vérifiées par le constructeur métallique et/ou le concepteur et, le cas échéant, modifiées de son propre chef pour s'assurer qu'elles concordent avec le projet concerné et qu'elles répondent aux exigences techniques spécifiques ainsi qu'aux dispositions légales et réglementaires.

Lors de la vérification, de la planification spécifique et de la mise en œuvre, il y a lieu de tenir compte des conditions spécifiques à l'objet (matériaux du bâtiment, dimension de l'élément d'insert, couleur, exposition, effet de charge, etc.) ainsi que de l'état actuel de la technique, y compris toutes les normes et directives techniques applicables.

En cas de divergence entre le présent document et la version allemande (no d'article K1179474), c'est dans tous les cas le texte original allemand qui prévaut dans sa version actuelle disponible dans le Jansen Docu Center.

Nous avons apporté le plus grand soin à l'élaboration de cette documentation. Cependant, nous déclinons toute responsabilité pour l'utilisation faite de nos propositions et de nos données.

Nous nous réservons le droit de procéder à des modifications techniques sans préavis.

Graphical planning data such as application examples, construction details, connections on site that are contained in our physical or electronic documentation components are schematic representations. The same applies to digital media such as CAD files or BIM models. They are intended to support the metal worker and/or design engineer in planning and executing projects. In the specific case of application they are to be checked by the metal worker and/or design engineer in terms of their usability in the specific project concerned with regard to legal/regulatory and technical property-specific requirements and adjusted if necessary at the latter's own responsibility.

The property-specific underlying conditions (construction material, dimensions of installation element, colour, exposure, load effect etc.) and current state of the art including all applicable norms and technical guidelines are to be taken into consideration at the metal worker and/or design engineer's own responsibility during the review, specific planning and implementation.

If there are any differences between this document and the current German version (item number K1179474), the latest version of the original German text in the Jansen Docu Center shall prevail.

All the information contained in this documentation is given to the best of our knowledge and ability. However, we decline all responsibility for the use made of these suggestions and data.

We reserve the right to effect technical modifications without prior warning.

Jansen AG

Steel Systems
Industriestrasse 34
9463 Oberriet
Schweiz
jansen.com

JANSEN